

**STORNOPHONE 5000
TONE EQUIPMENT**

Service Coordination.

Date: 01.85

Edition: 3

Publication no: 8311.5000-02

CONTENTS

SU5001/5002:	GROUP CALL/ALL CALL UNIT
SU5003:	SWITCHING UNIT
SU5004:	BUSY LAMP UNIT
SU5005:	ID-TONE CODE SELECTOR
TT5003:	TOUCH TONE GENERATOR
TQ5001/5002:	SEQUENTIAL TONE UNIT CODING AND STRAPPING
TQ5003:	CHANNEL GUARD UNIT - SINGLE TONE
FN5001:	SINGLE TONE REJECT FILTER
TT5001:	SINGLE TONE ENCODER
TR5001:	SINGLE TONE DECODER
TQ5004/5005:	SEQUENTIAL TONE UNIT LOGIC CONTROLLED CODING AND STRAPPING
TQ5006:	PROGRAMMABLE CHANNEL GUARD
FN5002:	CHANNEL GUARD TONE REJECT FILTER
TT5002:	CHANNEL GUARD ENCODER
TR5002:	CHANNEL GUARD DECODER
TQ5007/5008:	PROGRAMMABLE TONE BOARD

GROUP CALL UNIT SU5001

ALL CALL UNIT SU5002

The All-Call unit, SU5002, and Group Call unit, SU5001, are identical except for some few points. The following description will therefore apply to both SU5001 and SU5002, and their differences will be described in an appendix. All notes in this description refer to the schematic diagram.

General

The call unit is a single tone receiving module designed for application in TQ5001/2 and extend the selective calls to comprise group calls with one group tone. The module is a printed board with plug-in pins fitting sockets on the TQ5001/2. When fitted with a SU5000, TQ5001/2 is capable of receiving calls with a group call tone as the 3rd, 4th, or 5th tone of the sequential tone signal corresponding to the selected group division. Functionally the SU5000 is in parallel with the selection circuit of the individual call channel and the two circuits share the input amplifier/limiter. Two tones may be selected as the group tone, 2400Hz or 2800Hz, corresponding to individual digit 0 and alarm tone G, respectively.

A receiver group call is read out like an individual call with the following exceptions:

- 1: The audio channel can not be blocked with LS in/out.
- 2: The Automatic Receipt is blocked and Tone Keying is not possible.

The blockings are all cancelled approximately 500 milliseconds (ms) after the group call is terminated. Also see notes on TQ5001/2 schematic.

Mode of Operation

Upon reception of a sequential tone signal matching the tone combinations of TQ5001/2 and SU5001 the operation is as follows:

The r. f. carrier opens the squelch circuit which energizes the SQ-delay.

The sequential tone signal is amplified and limited in the input stage after which the

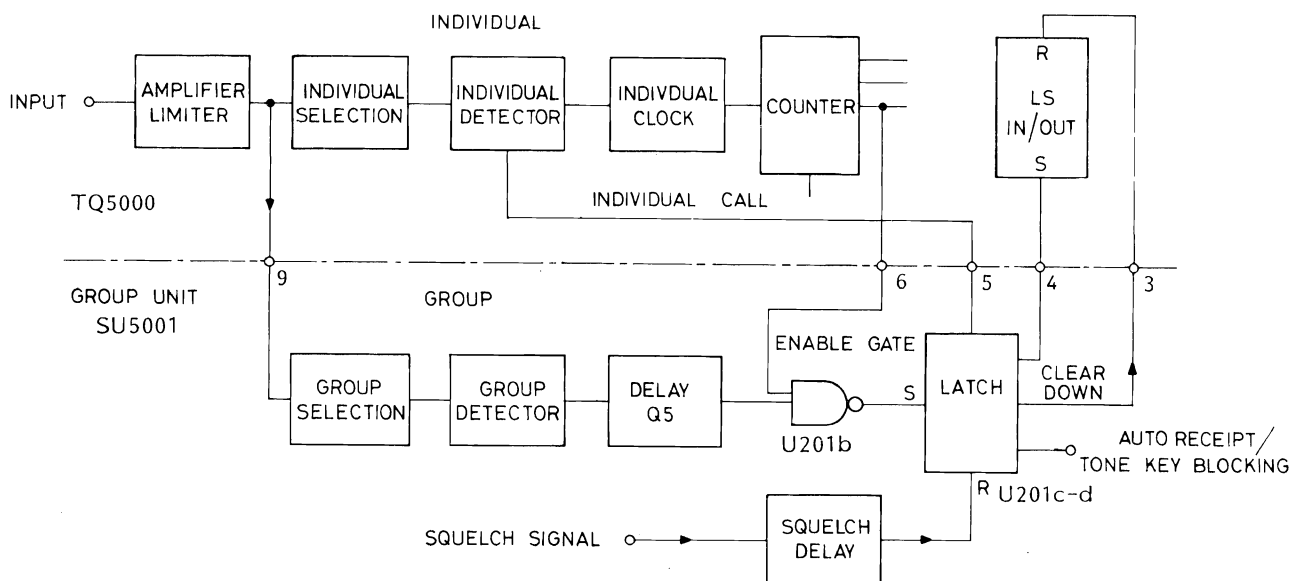

signal is applied to the resonant circuits of TQ5001/2 and SU5000. When the individual counter of TQ5001/2 has registered the first tones of the signal it releases the SU5000 to read out the group digit. The group tone is selected by the bandpass filter and applied to the detector. If the group tone level is within the sensitivity range of SU5000 the signal activates the detector circuit. The rectified signal from the detector is delayed approx. 25ms before the latch read out the call to TQ5001/2 along with establishing the blocking functions. Approximately 15 to 20ms after the end of the group tone the detector and delay circuits revert to standby. Approximately 500ms after the squelch closes, all blocking signals are cancelled and the loudspeaker is turned off.

Circuit Description:

Resonant Circuit

Transistor Q201 operates as a current generator and drives the resonant circuit L201-C201. The sensitivity and thus the bandwidth of SU5000 can be adjusted with resistor R201. (Note 3). The resonant circuit is a bandpass configuration and drives the detector circuit directly. The unit can be set to one of two tones, 2400Hz and 2800Hz. (NOTE 1 and 2)

Detector

The transistors Q202 and Q203 are arranged to form a differential detector circuit. In standby transistor Q202 is off, Q203 is on, and C202 is charged up to the potential determined by voltage divider R206-207. If the peak value of the selected signal exceeds the bias of Q202 (Q203's base voltage) Q202 turns on and charges C202 to a higher potential by which Q203 is biased off. At the cessation of the group tone C202 discharges via R204 and after approximately 10-20ms Q203 again turns on and holds the voltage on C202.

Delay and Enable Gate

Transistor Q204 operates as a switch and is controlled directly by the detector. In standby Q204 is on and the charge of C203 is neutral. When the detector is energized by a call Q204 goes off and C203 charges through R208// R209. After approximately 25ms (adjustable with R209) the voltage across C203 reaches the trigger level of U201a which relays the call information (+ 8, 5V) to enable Gate U201b.

If U201b has received a signal indicating that the first tones of a signal is accepted and counted by the individual Counter the call is applied directly to the Latch.

At the end of the group tone C203 discharges through R210 and U210a-b reverts to standby.

Latch and Squelch Delay

The latch is constructed as an R-S flip-flop employing gates U201c and U201d.

The latch reads out the group call to the individual tone receiver TQ5001/2 and, simultaneously, establishes the blocking functions:

- Pin 4: common terminal for individual and group call blocking of the LS in/out. Diode D203 is forward biased.
- Pin 7: Blocking of Automatic Receipt and Tone Key.
Diode D201 tied to chassis through U201d.
- Pin 3: Tied to chassis through U201d.

The R-input of the Latch is controlled by the squelch via the Squelch Delay which cancels the blocking functions 500ms after the squelch closes. C205 charges through R214 and Q205 which is driven by the squelch buffer inverter of TQ5001/2. The voltage across the capacitor is maintained until the squelch closes after

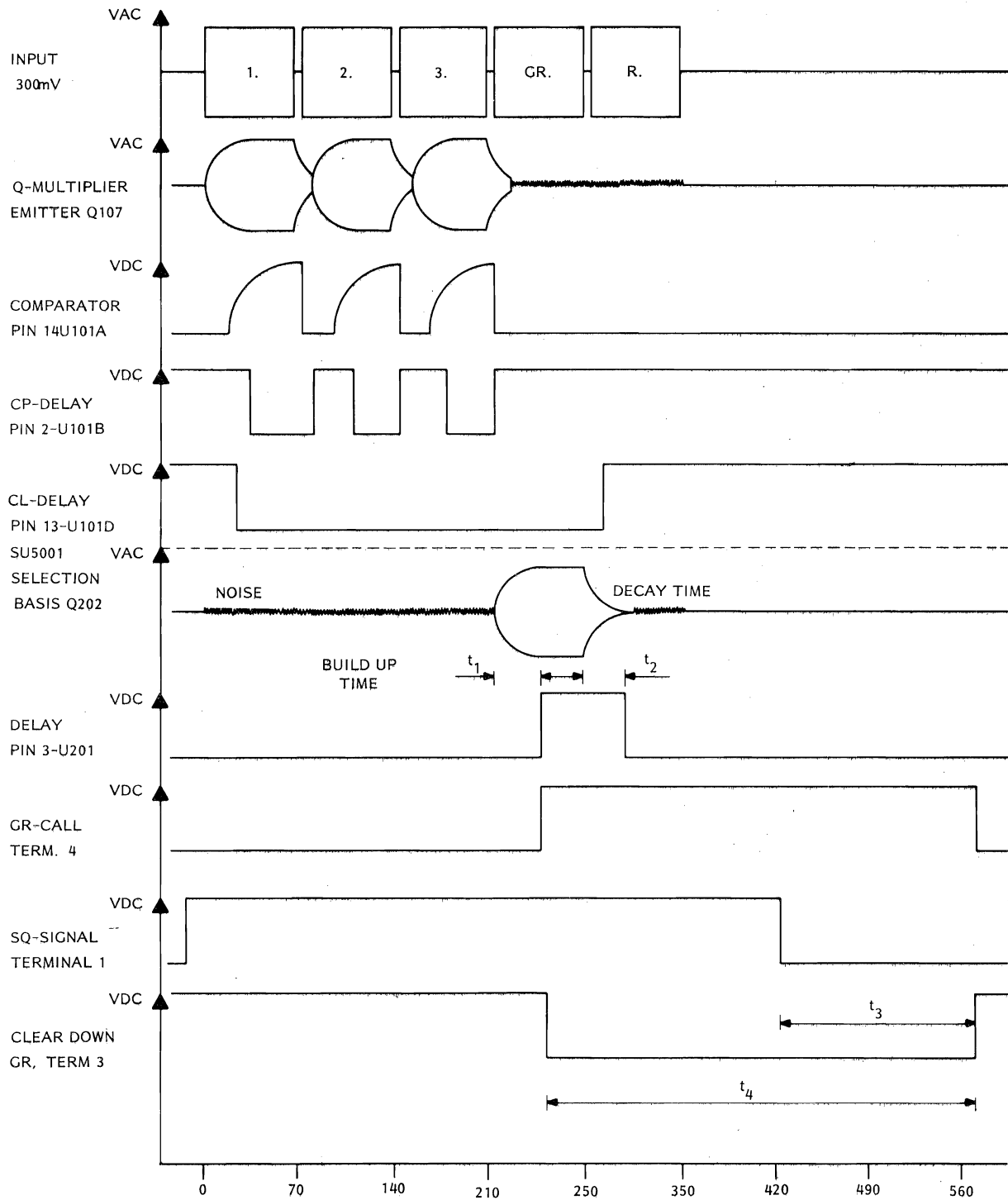

t_1 BUILD-UP TIME DELAY
 t_2 DELAY TIME HANG TIME
 t_3 SQ-DELAY
 IN PERIOD t_4 THE AUTOMATIC RECEIPT TONE KEY AND LS IN OUT ARE INHIBITED.

which C205 is discharged by R214 and R215. At the end of the group tone Enable Gate U201b reverts to standby.

The latch information is held by the Squelch Delay for approximately 500ms after the squelch has closed and then the blockings are cancelled.

- Pin 4: 0V, R = R212
- Pin 7: D201 submits a positive pulse to turn off the loudspeaker.

Coding Sequential Tone Call Signals

With One Group Tone

If digit 0 (2400Hz) is used (group call according to ZVEI), there are limitations to the number of individual call combinations, as the SU5001 responds to individual tone combinations containing the digit 0. Likewise a sequential tone signal must not contain two identical, consecutive tones for which reason digit 0 cannot be used as the last digit of a group number.

Note

The tone ahead of the group tone and the following tones must not be coded to 0. If tone G is used (2800Hz), which is outside the tone series employed (0-9), there are no limitations in the number of individual and group combinations.

The Group Digit Location

a: SU5001 strapped to 2400Hz (=digit 0).

5-digit sequential tone signal with group call on 5th digit

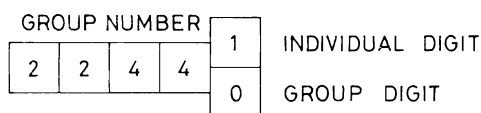

9 individual numbers from 22441 to 22449

5-digit sequential tone signal with group call on 4th digit

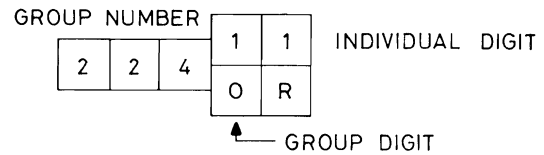

81 individual numbers from 22411 to 22499.

5-digit sequential tone signal with group call on the 3rd digit

(non standard according to ZVEI)

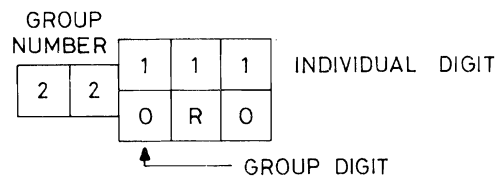

729 individual numbers from 22111 to 22999

The group call combination is emitted as shown above, but the digits following the group digit (0) have no functions in the call configuration.

b: SU5001 strapped to 2800Hz (=digit G)

5 digit sequential tone signal with group call on 5th digit

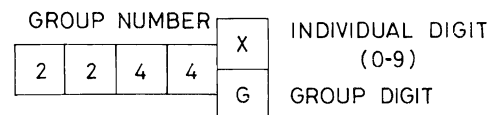

10 individual numbers from 22440 to 22449.

5-digit sequential tone call with group call on the 4th digit

5-digit sequential tone call with group call on the 3rd digit

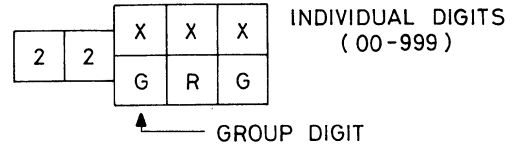
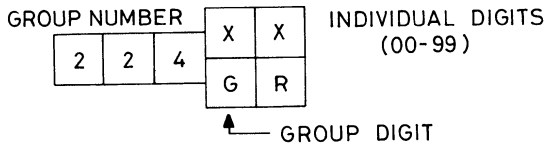

100 individual numbers from 22400 to 22499

1000 individual numbers from 22000 to 22999

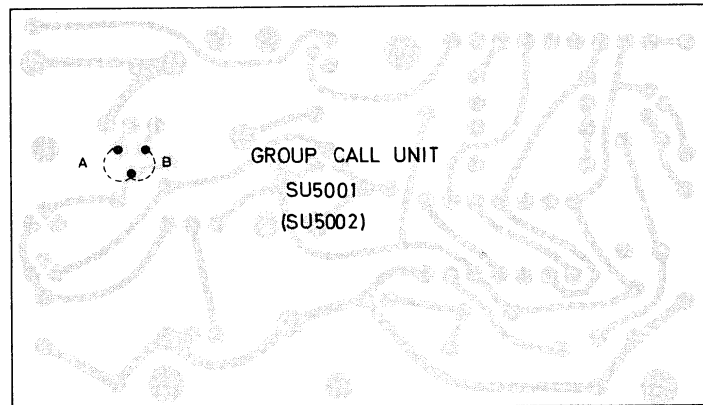
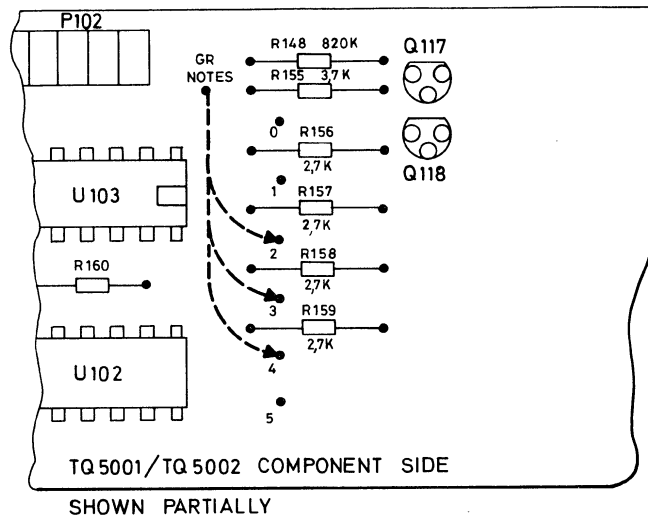

A = 2800 Hz (DIGIT G)
B = 2400 Hz (DIGIT O)

Part of component side TQ5001/2. See drawing and notes on the TQ diagram.

- NOTE 5 → 2: Group-Call on 3rd tone
- NOTE 5 → 3: Group-Call on 4th tone.
- NOTE 5 → 4: Group-Call on 5th tone.

Installation

The SU5000 is equipped with plug-in pins and can be inserted directly in the TQ5001/2. When inserted the straps in the connector P102 (on TQ5001/2) must be removed. See drawing and notes on the TQ diagram.

GROUP CALL UNIT SU5001

Technical Specifications

Supply Voltage

8.5V \pm 0.25V

Current Drain

Standby: 0,5 mA (no external load)

Engaged: approx. 0,65 mA (with SQ signal)

Temperature Range

30⁰C to +60⁰C

Input Specifications

See input specifications of TQ5001/TQ5002.

Activating Signal

Single tone signal of 55 ms duration. The location of the group tone is coded on the TQ5001/TQ5002.

Tone Frequencies

2400Hz, 2800Hz.

Frequency Accuracy

\pm 0.3%

Selectivity

SU5001 responds to frequency deviations \pm 1.4%.
SU5001 is insensitive to adjacent tones of the same standard series.

Reaction Time

30ms \pm 5ms (adjustable).

Signal to Noise Conditions

SU5001 can, in conjunction with TQ5001/TQ5002, process signals having a noise level corresponding to SINAD = 5dB as measured in the speech channel of the CQM5000.

Clear Down Time

< 30ms.

Output Functions

The TQ5001/TQ5002 output functions corresponds to an individual call with the following exceptions:

LS in/out Latch Blocking: After a group call the loudspeaker cannot be turned off manually.

Auto Receipt Blocking: After a group call the automatic receipt function is inhibited.

Tone Key Blocking: After a group call the tone key function is blocked.

Group Call Clear Down: Approx. 500ms after the receiver squelch closes, the blocked functions are released and the loudspeaker is turned off.

Dimensions

Width: 41 mm

Length: 72.5 mm

Weight

20 g

GROUP CALL UNIT

SU5002

Technical Specifications

Supply Voltage8.5V \pm 0.25VCurrent Drain

Standby: 0.5 mA (no external load)

Engaged: approx. 0.65 mA (with SQ signal)

Temperature Range

-30°C to +60°C.

Input Specifications

See input specifications of TQ5001/TQ5002.

Activating Signal

Single tone signal of minimum 2 seconds duration.

The location of the 'all call tone' is coded on the TQ5001/TQ5002.

Tone Frequencies

2400Hz, 2800Hz

Frequency Accuracy \pm 0.3%SelectivitySU5002 responds to frequency deviations \pm 1.4%.

SU5002 is insensitive to adjacent tones of the same standard series.

Reaction Time2 seconds \pm 0.25 sec. (adjustable).Signal to Noise Conditions

SU5002 can, in conjunction with TQ5001/5002, process signals having a noise level corresponding to SINAD = 5 dB as measured in the speech channel of CQM5000.

Clear Down Time

< 30ms.

Output Functions

The TQ5001/TQ5002 output functions corresponds to an individual call with the following exceptions:

LS in/out Latch Blocking: After an all-call the loudspeaker cannot be turned off manually.

Auto Receipt Blocking: After an all-call the automatic receipt function is inhibited.

Tone Key Blocking: After an all-call the tone key function is blocked.

All Call Clear Down: Approx. 500ms after the receiver squelch closes, the blocked functions are released and the loudspeaker is turned off.

Dimensions

Width: 41 mm

Length: 72.5 mm

Weight

20 g

AppendixSU5002

An "All-Call" is emitted as a single tone of more than two seconds duration. In SU5002 both tones, 2400Hz or 2800Hz, may be used (digit 0 or digit G) The only difference between SU5001 and SU5002 is the time delay that determines the reaction time (C203, R208, R209). With a reaction time of two seconds it is possible to transmit a normal sequence call including the All-Call tone without activating the unit.

Coding

For Coding TQ5001/2 to correspond with SU5002:
Strap NOTE5 O.
See coding for Group Call.

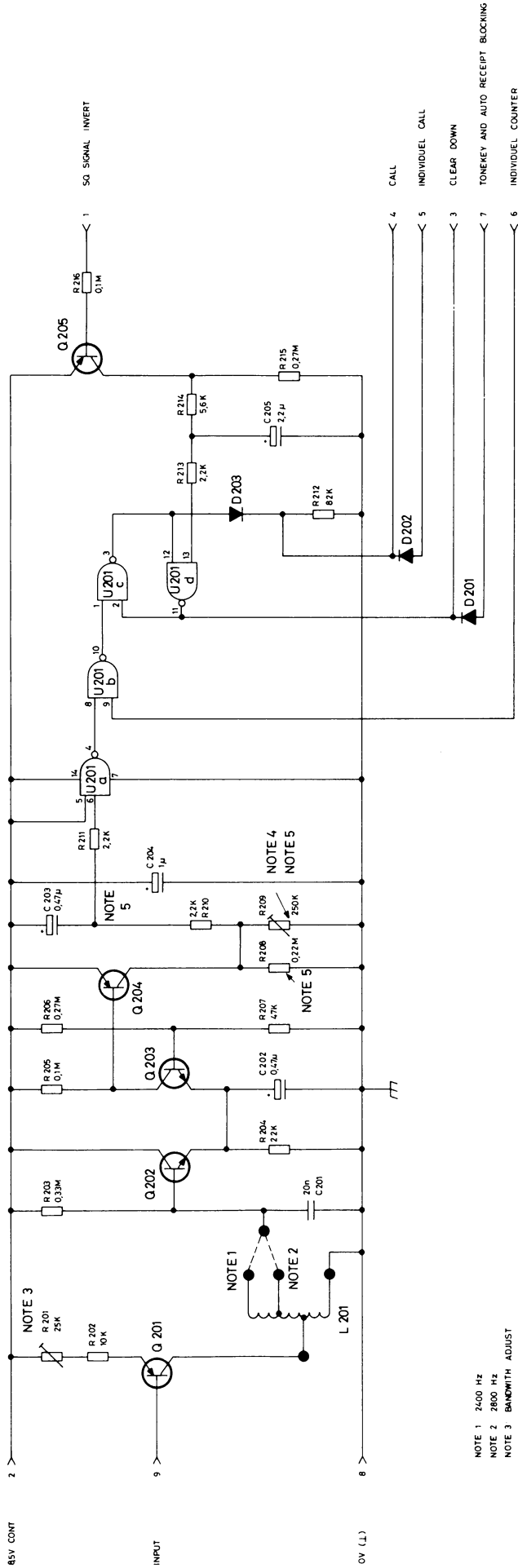

- NOTE 1 2400 HZ
- NOTE 2 2800 HZ
- NOTE 3 BANDWIDTH ADJUST
- NOTE 4 SET UP TIME ADJUST
- NOTE 5 FOR SU 5002
- R 208 = 056 M
- R 209 = 500 K
- C 203 = 80UF/16V

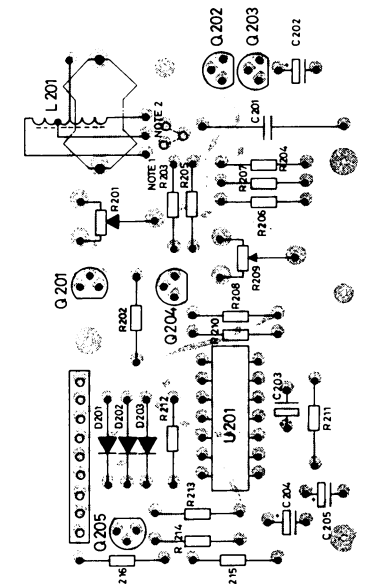

GROUP CALL - ALL CALL UNIT
 SU 5001, SU 5002

D402.620

Storno

TYPE	Nº	CODE	DATA
SU5002	C202	73. 5125	0. 47 uF 20% Tantal
	C203	73. 5109	10 uF 20% Tantal
	C204	73. 5114	1 uF 20% Tantal
	C205	73. 5102	2. 2 uF 20% Tantal
	C210	76. 5127	20 nF 2% Polystyr. TB
	D201	99. 5237	1N4148 Diode
	D202	99. 5237	1N4148 Diode
	D203	99. 5237	1N4148 Diode
	L1	61. 1358	Tone coil
	Q201	99. 5237	BC308 Transistor
	Q202	99. 5143	BC238 Transistor
	Q203	99. 5143	BC238 Transistor
	Q204	99. 5237	BC308 Transistor
	Q205	99. 5237	BC308 Transistor
	R201	86. 5054	25 Kohm 20% Carbon pot.
	R202	80. 5260	10 Kohm 5% Carbon film
R203	80. 5282	560 Kohm 5% Carbon film	
R204	80. 5265	22 Kohm 5% Carbon film	
R205	80. 5273	100 Kohm 5% Carbon film	
R206	80. 5278	270 Kohm 5% Carbon film	
R207	80. 5269	47 Kohm 5% Carbon film	
R208	80. 5277	220 Kohm 5% Carbon film	
R209	86. 5038	500 Kohm 20% Carbon pot.	
R210	80. 5253	2. 2 Kohm 5% Carbon film	
R211	80. 5253	2. 2 Kohm 5% Carbon film	
R212	80. 5272	82 Kohm 5% Carbon film	
R213	80. 5253	2. 2 Kohm 5% Carbon film	
R214	80. 5258	5. 6 Kohm 5% Carbon film	
R215	80. 5278	270 Kohm 5% Carbon film	
R216	80. 5273	100 Kohm 5% Carbon film	
U201	14. 5051	4011 Quad-2-inp. NAND	

35 V
16 V
35 V
35 V
63 V

0. 05 W
0. 125 W
0. 125 W
0. 125 W
0. 125 W
0. 125 W
0. 125 W
0. 05 W
0. 125 W
0. 125 W
0. 125 W
0. 125 W

Storno

TYPE	Nº	CODE	DATA

GROUP CALL UNIT SU5001

ALL CALL UNIT SU5002

X402. 649

SWITCHING UNIT

SU5003

The SU5003 switching unit is used as driver for an alarm device, horn, buzzer, bell, etc., or as a broadcast radio muting switch. The unit comprises a timer circuit and a relay with one changeover contact set. The unit is triggered by the CQM5000, either the tone receiver, or the squelch circuit and the monostable multivibrator timer sounds the alarm device for a preset time, approximately 1 second.

ALARM

A horn or bell is connected to the relay and the SU5003 is controlled by the alarm output

of the CQM5000 (pin 2 on J910). The alarm will be on for approximately 1 second.

BROADCAST RADIO MUTING

The unit is connected to the muting output on the CQM5000 (pin 9 on J910) which actuates the relay when the TQ5001/TQ5002 opens the AF output. In radiotelephones without tone equipment the relay will be activated whenever the squelch circuit is opened or the transmitter is keyed. The broadcast radio supply voltage is applied via the relay contacts that are normally closed, or its loudspeaker is disconnected.

TECHNICAL SPECIFICATIONS

Supply Voltage

10.8 V to 16.6 V

Current Drain, 13.2 V

Standby: approximately 0 mA

Engaged: 140 mA

Relay Contact Current

Max. 16 A (time less than 3 seconds)

5 A continuously

One change over contact set

Input

Alarm: A short pulse grounding the input terminal will actuate the relay for approx. 1 second.

Mute: A ground connection will actuate the relay.

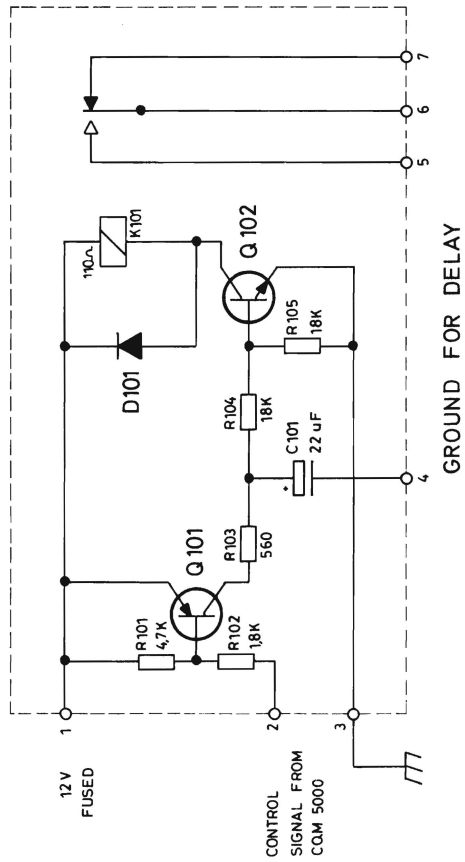

ALARM (HORN, BELL)

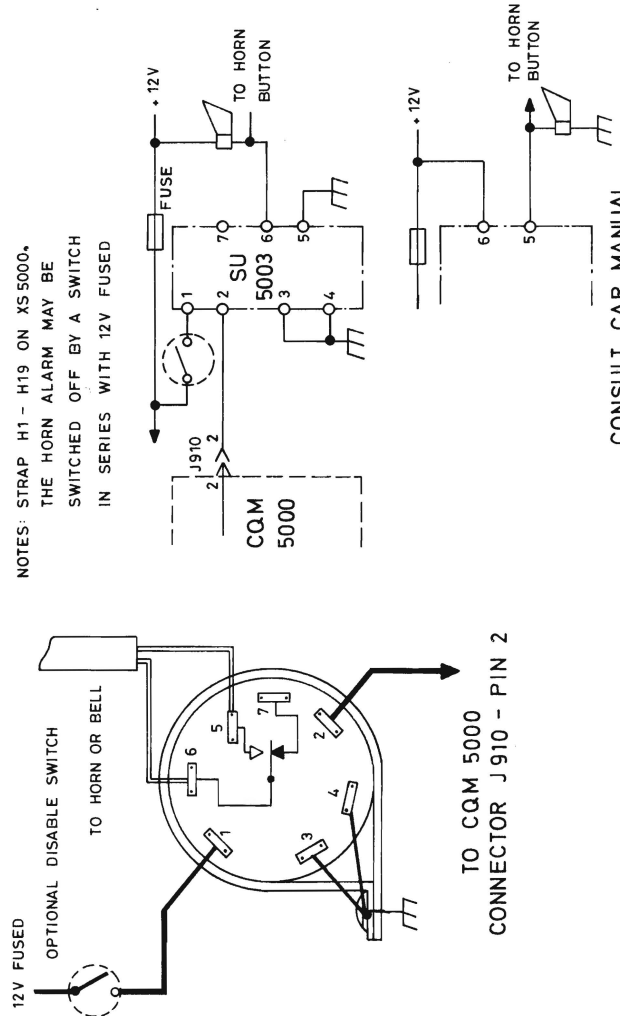

CONSULT CAR MANUAL FOR HORN SCHEMATIC

BOTTOM VIEW

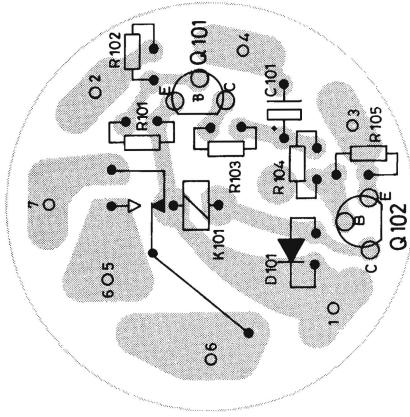

PRINTED CIRCUIT VIEWED FROM SOLDER SIDE

DISCONNECTING AUTO BROADCAST RADIO

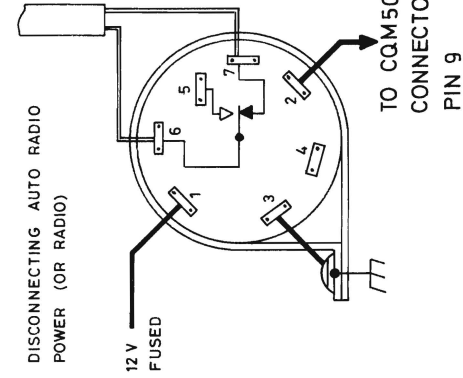

DISCONNECTING AUTO RADIO POWER (OR RADIO)

12V FUSED

TO CQM 5000 CONNECTOR J 910 PIN 9

NOTES: STRAP H20 - H33 ON XS5000.
 J910 - PIN 9 IS NOT FREE IF A CHANNEL GUARD / PILOT TONE UNIT IS CONNECTED TO J905.
 J911 PIN6 MAY BE USED IN THESE CASES (REMOVE STRAP H12 - H24 IF ANY) AND STRAP H20 - H12.

TO CQM 5000 CONNECTOR J910 - PIN 2

Storno

TYPE	Nº	CODE	DATA
	C101	73.5174	22uF, 20%, Tantal
	D101	99.5237	1N4148, Diode
	FB102	65.5102	Ferrite bead
	FB103	65.5102	Ferrite bead
	FB103	65.5102	Ferrite bead
	K101	58.5083	12 V Relay, 110 ohm,
	Q101	99.5365	MPS-A13, Transistor
	Q102	99.5251	BC307, Transistor
	R101	80.5249	1 Kohm, 5%, Carbon film
	R102	80.5252	1.8 Kohm, 5%, Carbon film
	R103	80.5246	560 ohm, 5%, Carbon film
	R104	80.5264	18 Kohm, 5%, Carbon film
	R105	80.5264	18 Kohm, 5%, Carbon film
			0.125 W
			0.125 W
			0.125 W
			0.125 W
			0.125 W

Storno

TYPE	Nº	CODE	DATA
------	----	------	------

SWITCHING UNIT SU5003

X402.710/2

BUSY LAMP UNIT

SU5004

The busy lamp is a timer unit designed for application in CQM5000 with a TQ unit. SU5004 makes the transmit control lamp start flashing, when the channel is occupied and the loudspeaker is blocked by the TQ module.

SU5004 is a printed board with a timer circuit and 5 wires. It is mounted above the S601 and S602, push button switches, in the RF board, on a spacer. The 5 wires are soldered as follows on the RF board:

black	ground
orange	8.5 V RX
brown	D606 anode
red	Q604 collector
yellow	Q603 collector

MODE OF OPERATION

The timer goes on when Q1 is off, both inputs must be negative. Input 1 (yellow) wired to Q603 collector is negative when a noise signal is applied to the squelch circuit.

Input 2 (red) wired to Q604 collector is negative when RX mute is not activated. When either input 1 or input 2 goes positive, Q1 goes on, timer U1 ceases working and the transmit control lamp D606 stops flashing.

TECHNICAL SPECIFICATIONS

Supply Voltage

8.5 V \pm 150 mV

Current Drain

Standby: 14 mA

Engaged: 25 mA

Temperature Range

-30°C to +60°C

Output functions

Channel occupied and RX mute off makes the TX control lamp flashing.

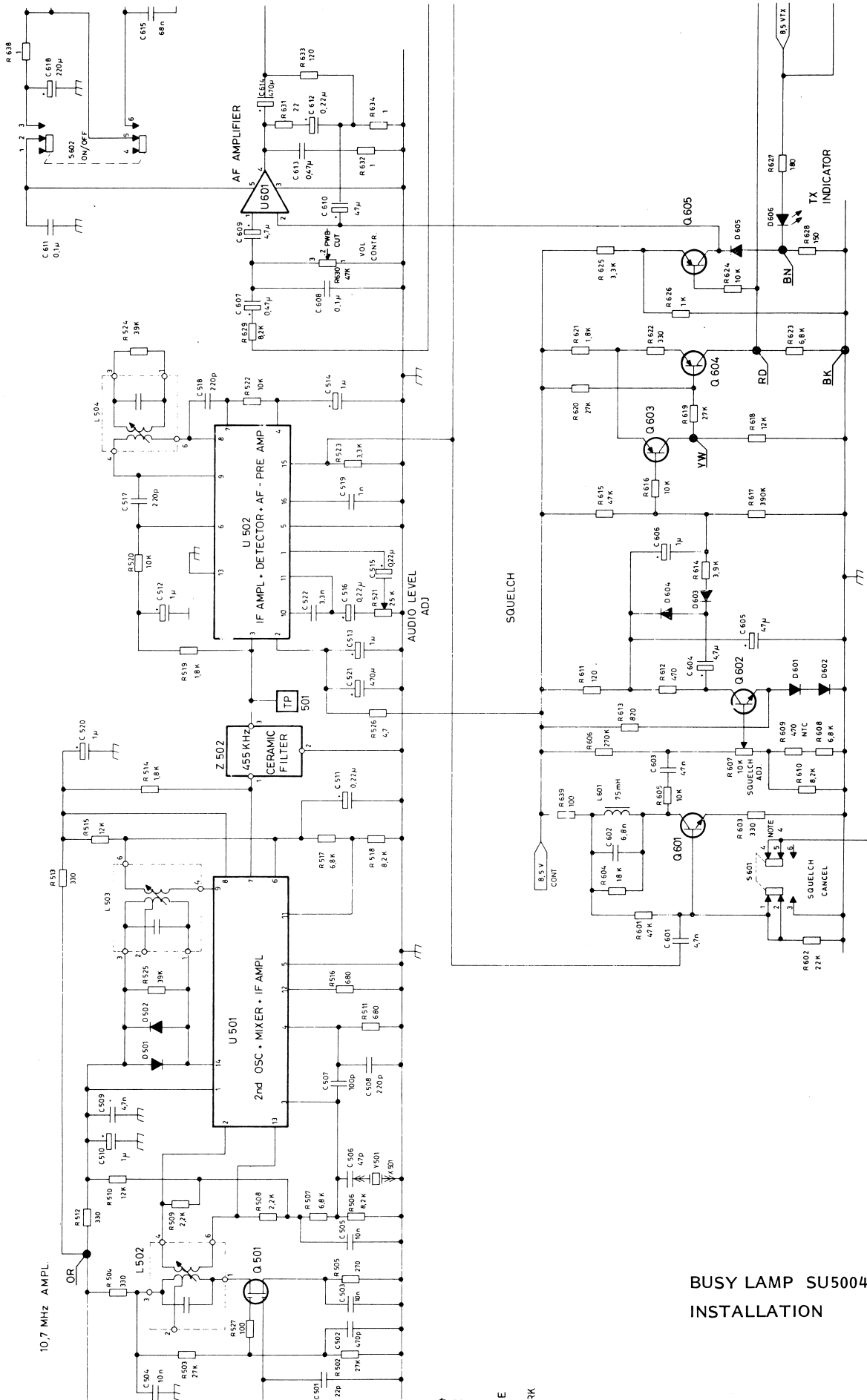

NOTE 4. STRAP 4-5 IN ALL RADIOS EXCEPT US VERSIONS.

BUSY LAMP SU5004
INSTALLATION

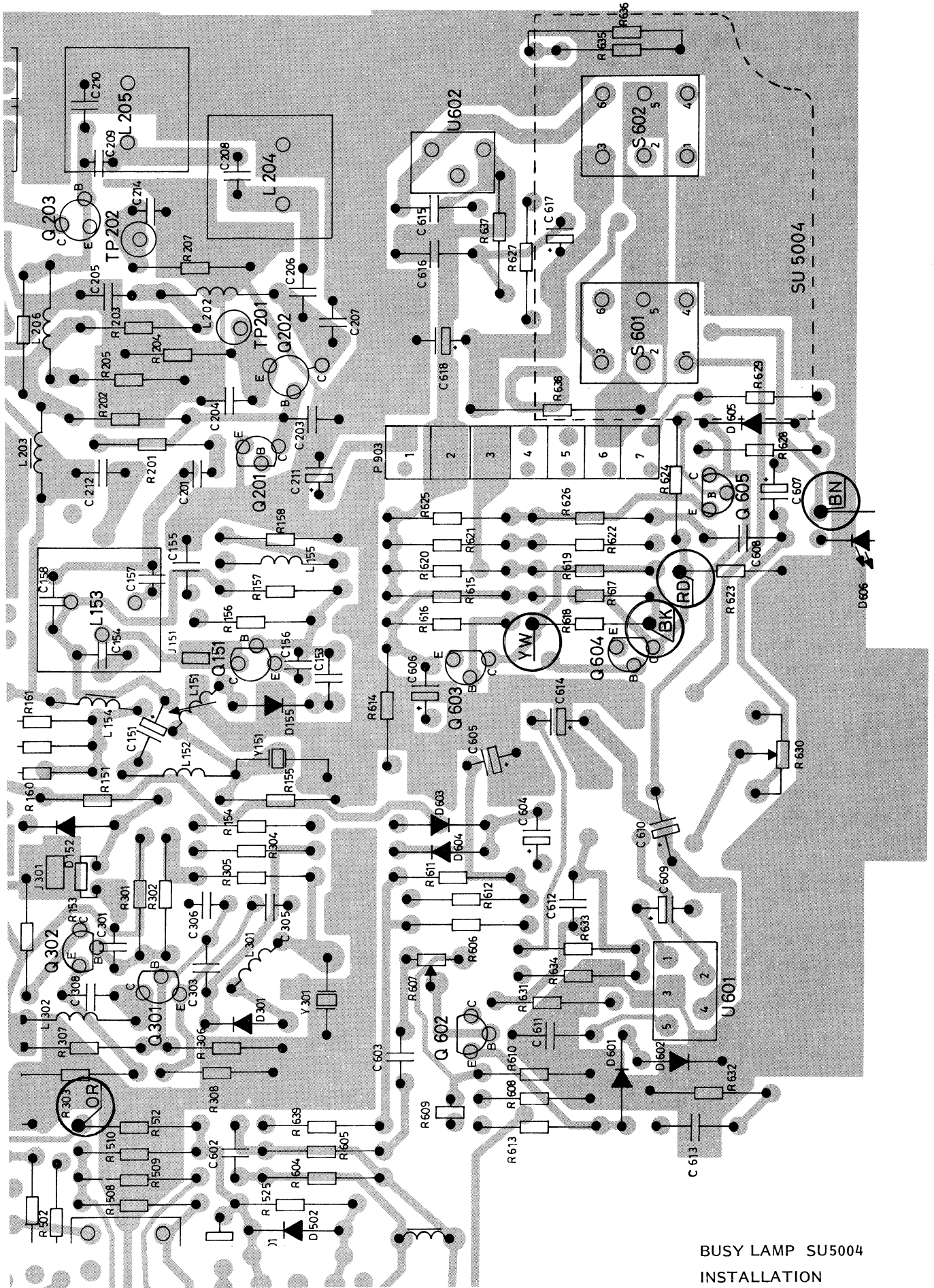

BUSY LAMP SU5004
INSTALLATION

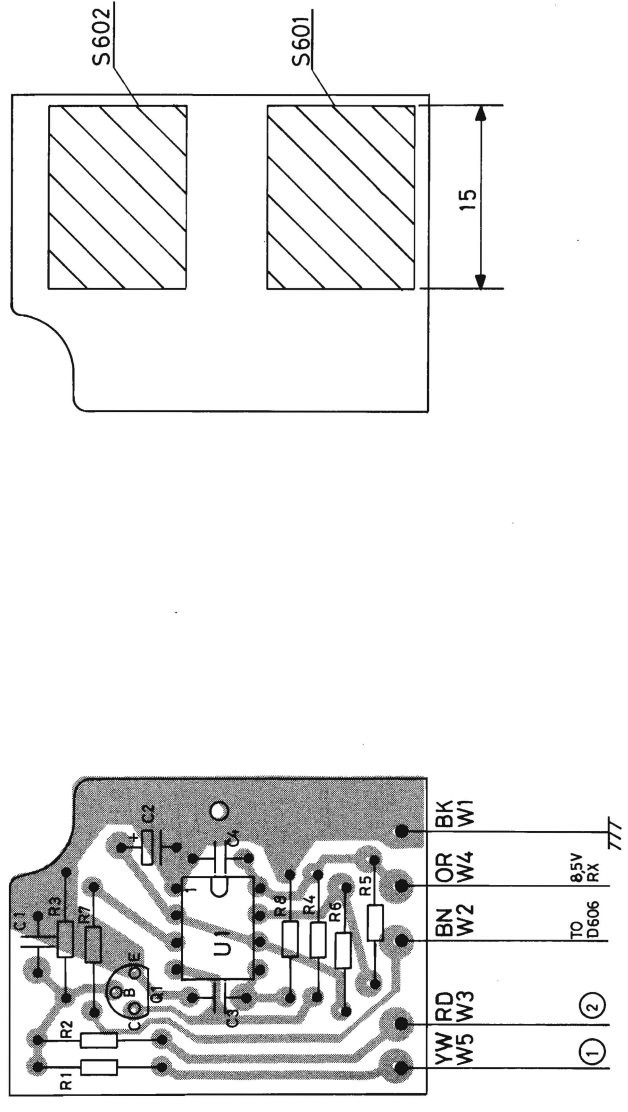
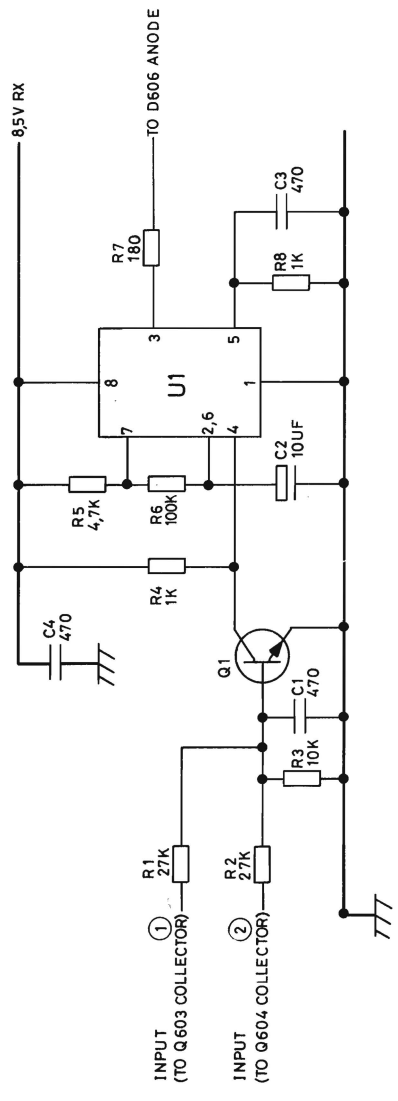

BUSY LAMP UNIT
SU5004

D402.916

Storno

Nº	CODE	DATA
C1	19A700233P5	470 pF Ceramic
C2	19A700003P7	10 uF Tantal
C3	19A700233P5	470 pF Ceramic
C4	19A700233P5	470 pF Ceramic
Q1	19A70001P1	BC548 Transistor
R1	19A700019P54	27 Kohm Depos
R2	19A700019P54	27 Kohm Depos
R3	19A700019P49	10 K Depos
R4	19A700019P37	1 Kohm Depos
R5	19A700019P45	4.7 Kohm Depos
R6	19A700019P61	100 Kohm Depos
R7	19A700019P28	180 Kohm Depos
R8	19A700019P37	1 Kohm Depos
U1	19A701865P1	NE555 Timer

50 V
16 V
50 V
50 V
0.25 W
0.25 W
0.25 W
0.25 W
0.25 W
0.25 W
0.25 W
0.25 W
0.25 W

Storno

Nº	CODE	DATA

BUSY LAMP UNIT SU5004

X403.001

10-TONE CODE SELECTOR

SU5005

The SU5005 is an optional board for transmitting up to 10 tone codes. The module is used in conjunction with tone modules TQ5001 and TQ5002 interconnect boards XS5003 or XS5005, and utilises the channel selector to select the tone codes. When the SU5005 is installed the radiotelephone can only be fitted with 1 RF channel.

MOUNTING

Disconnect the colour coded tone wires from the tone coil tap (10 pcs), terminal 1 through 14.

Mount the SU5005 board on switch S101 by soldering it to the unused terminals.

Put the wires that was unsoldered into the slot on the board except the GRAY, the BLUE and the VIOLET wire.

Solder wires to W12 to the taps on the tone coil as follows:

BROWN to tap 3	BLUE to tap 8
RED to tap 4	VIOLET to tap 9
ORANGE to tap 5	GRAY to tap 10
YELLOW to tap 6	WHITE to tap 11
GREEN to tap 7	BLACK to tap 12

Connect W11 from terminal R to tap 13.

Connect W12 from terminal A to tap 14.

For 12.5 kHz channel spacing systems the taps 1 and 2 are used instead of 13 and 14 respectively.

CODING

The coding of the tones is performed by soldering the free wires in the slot to the ter-

minals near the edge of the SU5005 board.

When coding the tone transmitter the wire representing the variable tone digit (V) is connected to terminal V.

Principally each of the five digits in the tone code can be chosen as variable but some limitations have to be considered.

If the tone code digits are designated A, B, C, D and E, the repeat tone R, and the variable digit V following combinations are not valid:

V - B - C - D - E	when V= B
A - V - C - D - E	when V= C
A - B - V - D - E	when V= D
A - B - C - V - E	when V= E
	when V is followed by R (repeat tone)

When the repeat tone R is used to replace a digit in the variable part of the tone code the printed conductor between the terminals carrying the replaced digit is cut. Terminal R is then connected to the terminal farthest from the printed wiring board edge.

When the repeat tone R is used in the fixed part of the tone code the wire is connected directly to terminal R.

CODING TWO TONE TELEGRAMS

The coding described above results in the tone call and auto receipt (acknowledge) codes being identical. If the tone module is coded according to the note on the tone module diagram the two functions are separated so that f. ex. acknowledge is a fixed code and the tone call is variable, or vice versa.

The tone button S101 is used directly to switch these functions and hence must be depressed during the sequence of transmitting a tone call, i. e. as long as the TX indicator is on.

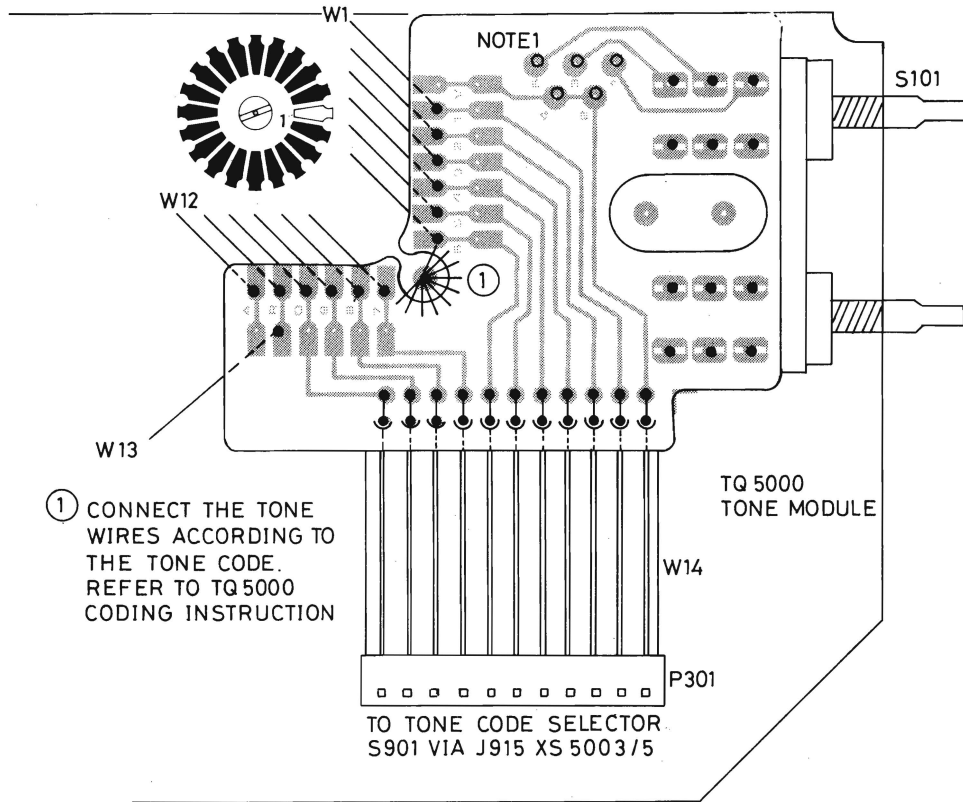

NOTE 1.

COMBINATION

- 1.1 SELECTABLE ACKNOWLEDGEMENT CODE -
SELECTABLE TONE CODE: CONNECT 2-4.
- 1.2 SELECTABLE ACKNOWLEDGEMENT CODE -
FIXED CALL CODE: CONNECT 1-5, 4-5, 3 TO FIXED DIGIT
- 1.3 FIXED ACKNOWLEDGEMENT CODE -
SELECTABLE CALL CODE: CONNECT 2-3, 4-5, 3 TO FIXED DIGIT

CUT PRINTED WIRE BETWEEN 2 AND 4
WHEN USING COMBINATION 1.2 OR 1.3.

10-TONE CODE SELECTOR SU5005
CODING INSTRUCTION

D403.120

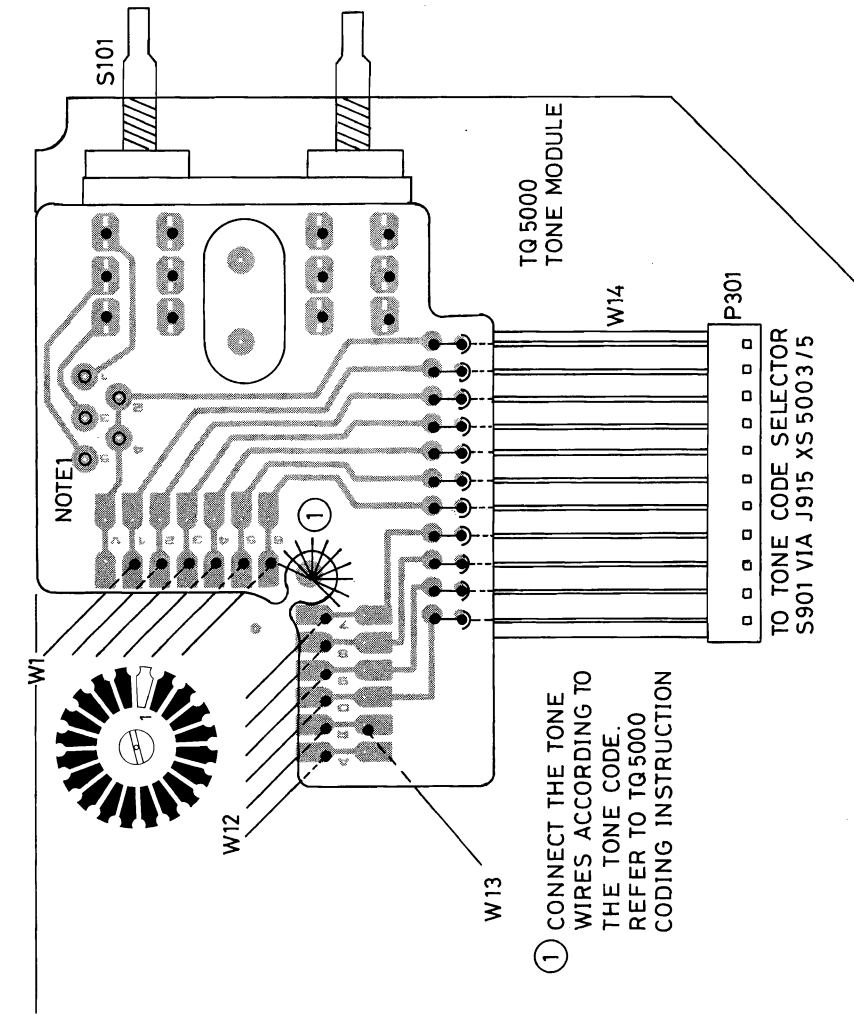

NOTE 1.

COMBINATION

1.1 SELECTABLE ACKNOWLEDGEMENT CODE -
SELECTABLE TONE CODE: CONNECT 2-4.

1.2 SELECTABLE ACKNOWLEDGEMENT CODE -
FIXED CALL CODE: CONNECT 1-5, 4-5, 3 TO FIXED DIGIT

1.3 FIXED ACKNOWLEDGEMENT CODE -
SELECTABLE CALL CODE: CONNECT 2-3, 4-5, 3 TO FIXED DIGIT
CUT PRINTED WIRE BETWEEN 2 AND 4
WHEN USING COMBINATION 1.2 OR 1.3.

10-TONE CODE SELECTOR SU5005
CODING INSTRUCTION

D403.120

TOUCH TONE GENERATOR

TT5003

The TT5003 is a Touch Tone® generator for STORNOPHONE 5000.

The unit is mounted on the Control Panel and consists of three sub-units:

- a 15-button keyboard
- a touch tone encoder board
- a timing and switching circuit

KEYBOARD

The keyboard is a 3x5 button cluster with two illuminating lamps. The current for the lamps flow through a transistor which is turned on by +8.5 V.

	Col. 1 1209 Hz	Col. 2 1336 Hz	Col. 3 1477 Hz	Col. 4 1633 Hz
Row 1 697 Hz	1	2	3	A
Row 2 770 Hz	4	5	6	S
Row 3 852 Hz	7	8	9	M
Row 4 941 Hz	*	0	#	(Blank)

Keyboard matrix

® Trade Mark registered by Bell Telephone Co.

The keyboard is terminated in a connector which is connected to the touch tone encoder.

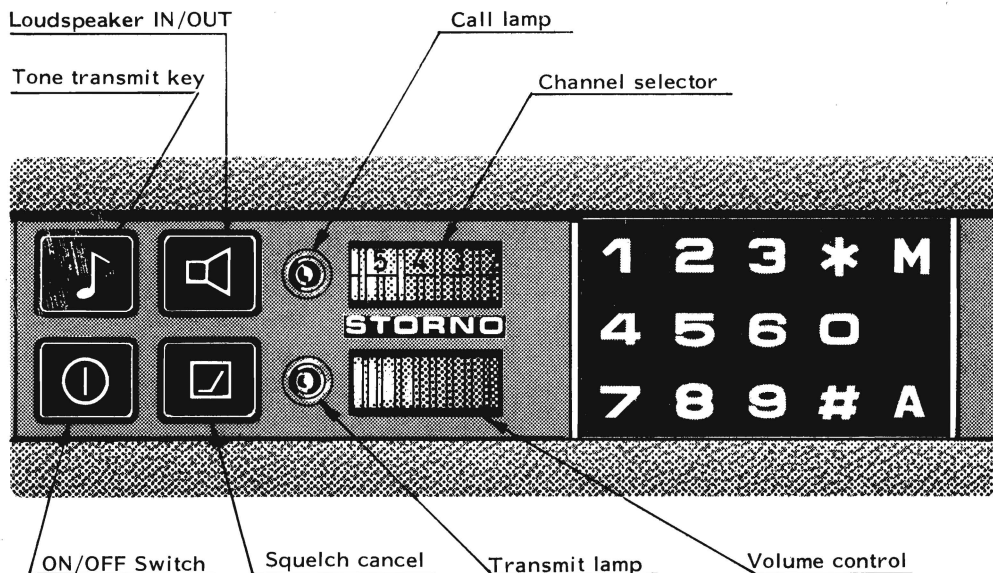

TOUCH TONE ENCODER

The touch tone encoder is an integrated circuit mounted on a board together with a 5 millisecond anti-bounce circuit, a busy indicator circuit and part of a circuit for extended "Clear Down" (#).

The tone encoder U201 is a 2 of 8 SINE WAVE GENERATOR which consists of a high frequency oscillator, two separate programable frequency dividers, a digital-to-analogue converter and a high level output driver. The reference frequency generator is fully integrated except for the 3.579545 MHz crystal. This fre-

quency is divided by 8 and then gated into two divide-by-N counters which provide the correct division ratios for the upper and lower band of frequencies. The output from these two counters are further divided by 8 to provide the time sequencing for a 4-voltage-level synthesis of each sine wave. Both sine wave signals are added and buffered to a high current output driver. C211 and C212 are external capacitors for low pass filtering which reduce the harmonic distortion of the output signal.

When depressing a keyboard button a logic "1" is available at the disable output of U201 tone encoder as long as the button is depressed. This output is used to trigger the delay circuit U202c to provide a delayed trigger pulse to the timing circuit.

The Busy Indicator circuit is triggered by the squelch and drives a LED on whenever a carrier is received. The circuitry consists of transistor Q201, amplifier U202d and transistor Q202. Capacitor C217 and amplifier U202d causes a delay of approx 11 seconds before turning the indicator off after the carrier has disappeared.

TIMING AND SWITCHING CIRCUITS

The trigger pulse from the tone encoder triggers two monostable flip-flops, U301a which has a delay time of approx. 100 milliseconds, and U301b which has a delay time of approximately 22 milliseconds. U301a controls the CG disable function (Q303), the microphone blocking function, the PTT (Push-To-Talk) function (Q304) and AF gate transistor Q305. U301b controls the time between pressing a button and generation of the tone modulation.

Transistor Q307 is an amplifier for the touch tone modulation and its output is set with potentiometer R322. A transistor Q306 is an amplitude limiter connected to the base of Q307.

The delay time of U301a may be extended to approx. 560 milliseconds by using the extended "Clear Down" function Q301. Transistor Q302 disables the touch tone generator whenever the RX mute output (connected to the touch tone disable input) goes low. This prevents that any attempt to operate the generator while receiving will energize the transmitter.

TECHNICAL SPECIFICATIONS

Supply voltage (+A)

13.2 V \pm 2.4 V

Supply voltage (8.5 V)

8.5 V \pm 0.15 V

Current drain (+A)

less than 130 mA

Current drain (8.5 V)

Busy indicator on: less than 37 mA

Quiescent: less than 12 mA

Anti-bounce delay

5 ms \pm 1 ms

PTT delay time

Normal: 100 ms \pm 20 ms

Extended: 560 ms \pm 100 ms

Touch tone delay

22 ms \pm 4 ms

Busy indicator off delay

11 sec. \pm 2 sec.

Crystal frequency

3.579545 MHz

Tolerance: 50×10^{-6}

Specification: S98-5038

Tone frequencies

Key	Low band Hz	High band Hz
1	697	1209
2	697	1336
3	697	1477
4	770	1209
5	770	1336
6	770	1477
7	852	1209
8	852	1336
9	852	1477
*	941	1209
0	941	1336
#	941	1477
A	697	1633
S	770	1633
M	852	1633

Maximum frequency deviation

$f_{nom} \pm 1\%$

Touch output levels

R322 set to max:

Low band: greater than 250 mV RMS

High band: greater than 400 mV RMS

Low + high

band: greater than 450 mV RMS

Variation between two combinations:

less than 1.5 dB

Distortion (THD)

Low band: less than 5%

High band: less than 3%

Output impedance

Higher than 15 Kohm

DC output loading

PTT (J307-7)

MIC. Block (J302-8)

I_{sink} less than 100 mA

CG disable (J302-10)

TT disable (J302-9)

I_{source} less than 10 mA

I_{source} less than 1.7 mA

Temperature range

-30°C to +60°C

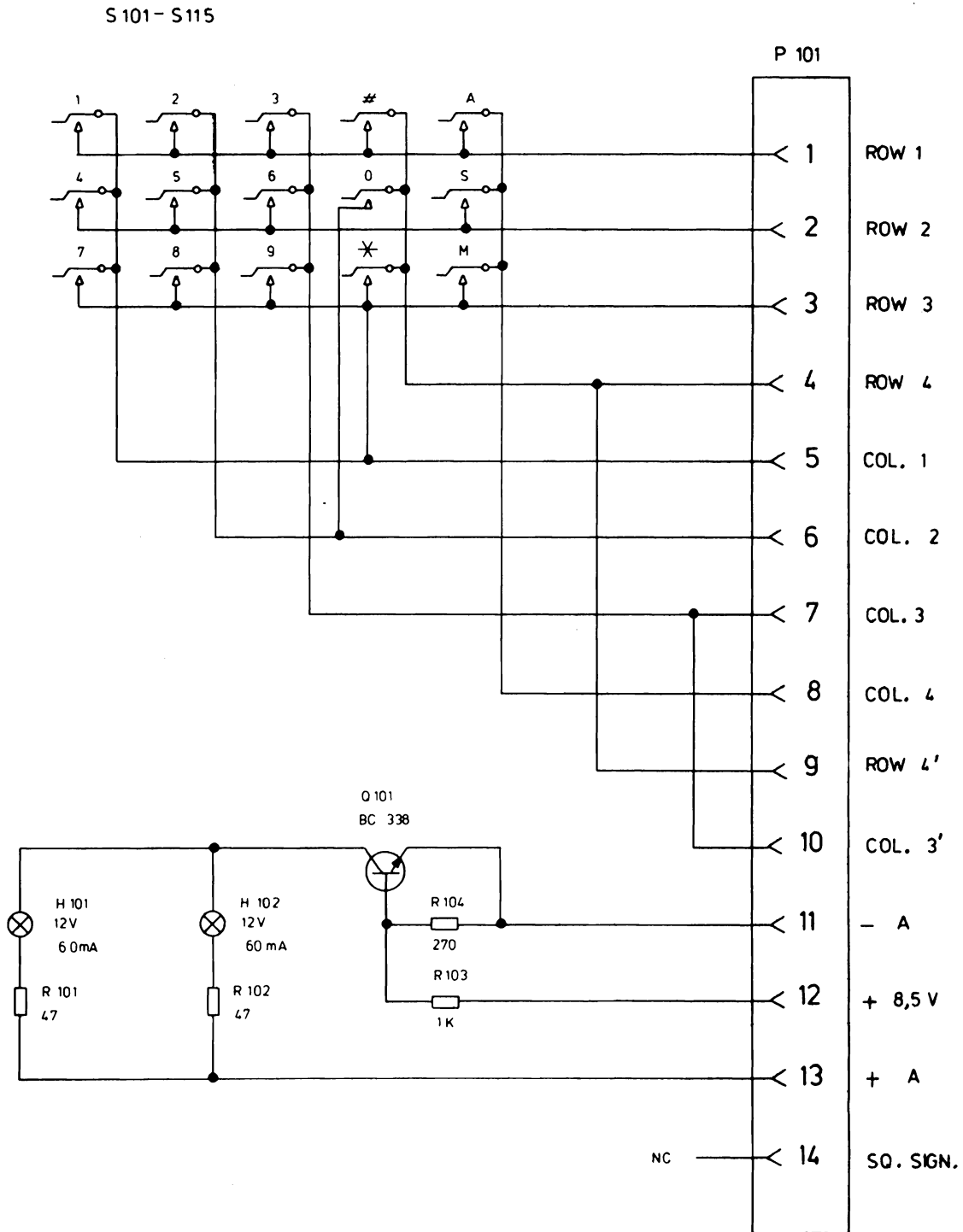

15.0428-00

TOUCH TONE GENERATOR TT5003
KEYBOARD

D403.160

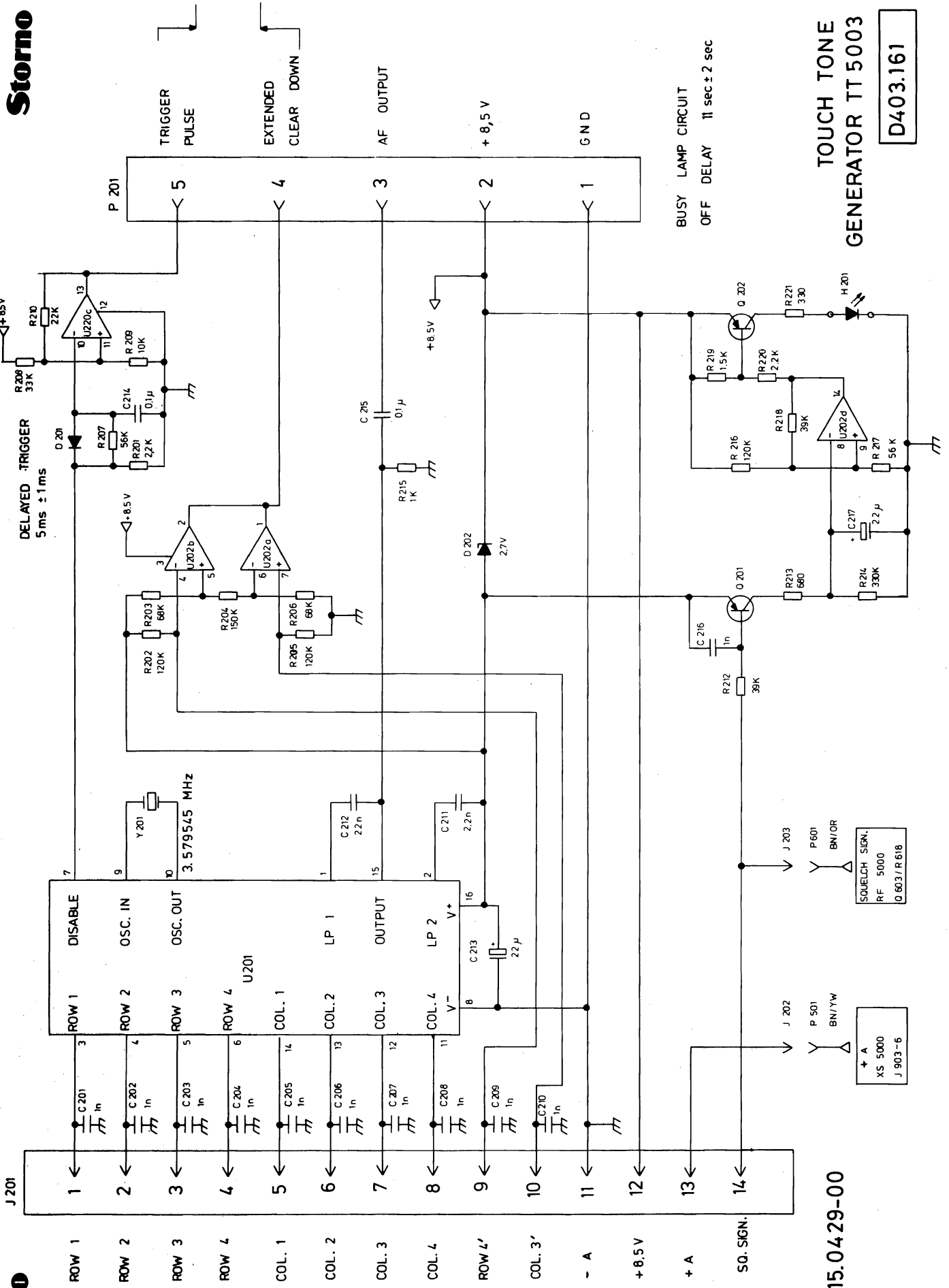

15.0429-00

TOUCH TONE GENERATOR TT 5003

D403.161

SOUELCH SIGN.
RF 5000
0.603/R.618

+ A
XS 5000
J.903-6

XS 5000
J 905

CG DISABLE

TOUCH - TONE
DISABLE

MIC. BLOCK
XS 5000
J 911-4

PTT

-A

+ 8.5 V

TOUCH - TONE
OUTPUT

AF GND

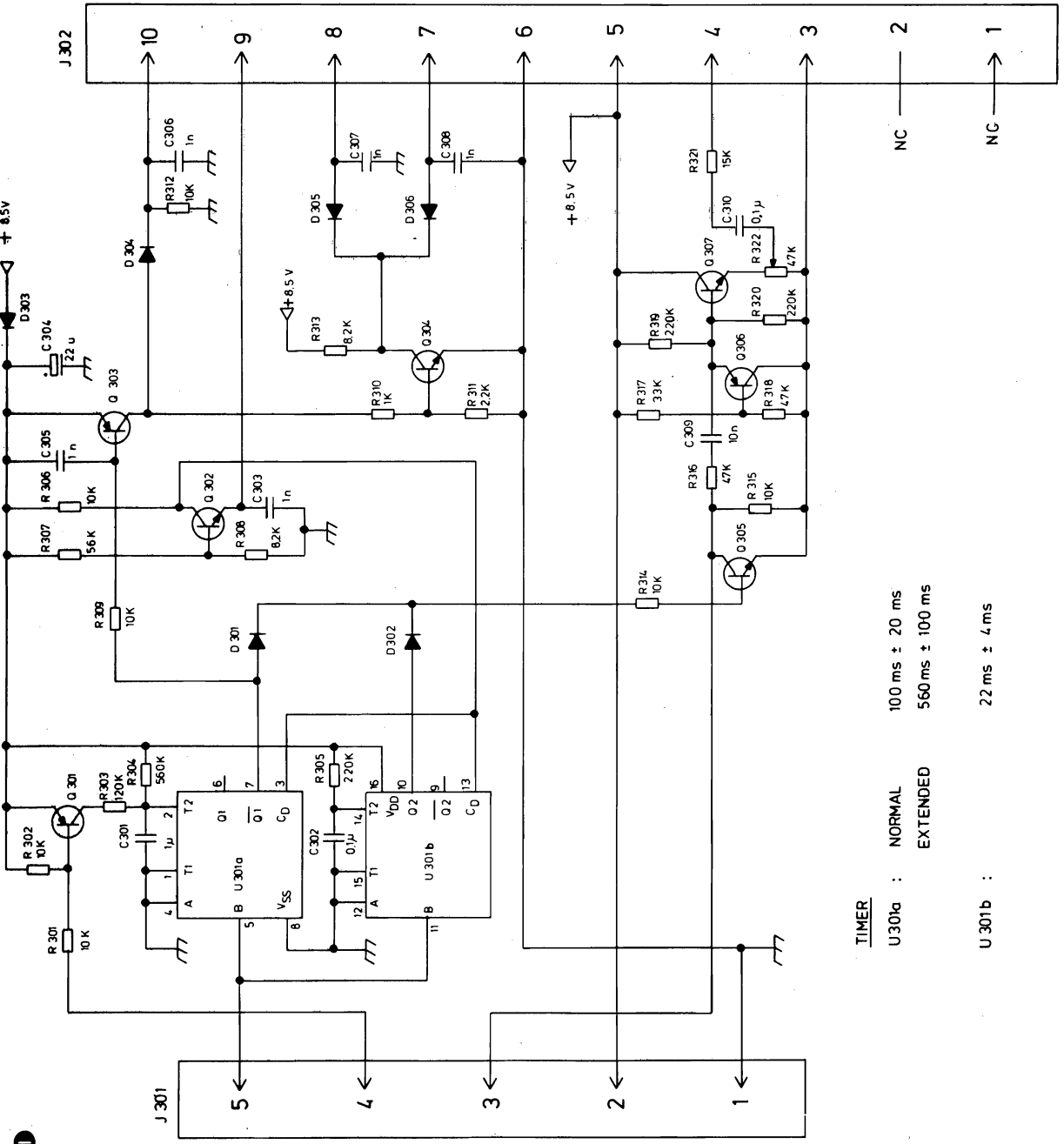
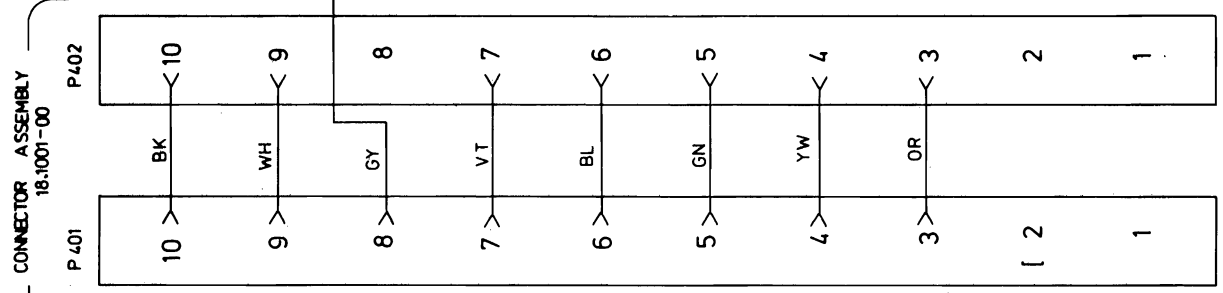

TIMER

- U 301a : NORMAL 100 ms ± 20 ms
- EXTENDED 560 ms ± 100 ms
- U 301b : 22 ms ± 4 ms

15.0430 - 00

TOUCH TONE GENERATOR TT 5003
TIMER

D403.162

SEQUENTIAL TONE UNIT

TQ5001 AND TQ5002

GENERAL

TQ5001 and TQ5002 are combined sequential tone transmitter-tone receiver units, the transmitter and receiver functions being independent of each other, and which can process 3, 4, or 5-tone signals. The units are designed to fit into CQM5000 radiotelephone equipment and the electrical design appears from the block diagram.

The unit is built on a single printed circuit board (p. c. b.) with plated through holes, and which connects to the radiotelephone circuits via plug-in sockets. The loudspeaker IN/OUT button, the TONE KEY button, and the green call indicator is mounted directly on the board and protrude through holes in the front plate. The unit is mechanical secured to the radiotelephone chassis by four screws and spacers.

For TQ5001 the tone frequencies are the STORNO series, 885 Hz to 2800 Hz; for TQ5002 the tone frequencies are the CCIR series, 960 Hz to 2110 Hz. The tone combinations for the tone receiver and the tone transmitter are selected by soldering colour coded wires to the tone coil, or by establishing the connections on the wiring side of the p. c. b. In standby, when turning on the equipment, the unit is in the tone receive mode and set to the 1st tone of the combination. Receipt of a sequential tone signal, that matches this combination, will cause the following events to take place.

The key blocking is cancelled (Q127 ON).
The loudspeaker blocking is cancelled (Q130 OFF).
The LED call indicator D107 will start flashing.

When the tone unit is strapped for Auto-Receipt, a correct tone call will automatically

trigger the sequential tone transmitter circuit and after having generated the last tone of the sequential tone signal the unit reverts to the condition described above, i. e. the loudspeaker is on.

Accordingly, when in the LS in mode, the tone transmitter can be manually triggered by pressing the Tone key button.

With 70 ms tone length, the time from depressing the Tone key to the generation of the 1st tone is approximate by 220 ms for TQ5001, and 320 ms for TQ5002.

ms = millisecond = 0.001 second.

When using 3 tones or 4 tones in the sequence this interval may be extended if the unused tone gate wires are left unconnected.

The transmitter remains keyed for approximately 640ms for TQ5001, and 920 ms for TQ5002 even if the Tone key button is pressed for a shorter or longer period. Simultaneously with the keying of the transmitter, the microphone amplifier will be blocked. The blocking signal disappears after the last tone has ceased, that is when the unit reverts to standby.

The units can accommodate a Group Call unit, SU5001, when an extension of the call tone system is required, and the unit may also be used as a combined single tone transmitter and sequential tone receiver.

MODE OF OPERATION

In standby the TQ5001/TQ5002 unit is set to the sequential tone receiver mode and when a tone signal having the proper code is applied to the input, the following events take place:
The 1st tone is amplified and limited in the input stage.

The signal is then, via a coupling link, applied to the selective circuit.

In standby the 1st tone gate, Q117, selects the 1st tone of the combination.

The active part of the selective circuit is a Q-multiplier, which also operates as oscillator when the selective circuit is part of the tone transmitter.

Owing to the high signal voltage across the selective circuit the gate transistors are biased in the nonconductive direction, and simultaneously the tone and oscillator signal amplitude is limited.

If the level of the 1st tone is within the sensitivity range of the tone receiver, the selected signal will switch the comparator output (U101A).

The schmitt-trigger (U101b) will go negative after approximately 17 ms which is generated by the Clock Delay circuit. At the same time the schmitt trigger rapidly charges the Clear Delay circuit in order to enable the counter.

At the end of the 1st tone the Schmitt trigger reverts to standby and the positive leading edge is fed to the counter's clock input. The counter steps forward and the next tone gate tunes the selective circuit to the 2nd tone.

Each gate transistor has its collector connected to one of the tone coil terminals. The sequential tone receiver is now set to receive the 2nd tone of the signal, and it remains in this state for approximately 120 ms, the time being determined by the Clear-Delay. Except for the requirement of a tone length of approximately 40 ms, the tone receiver is independent of the duration of the signal elements, because the counter switches to the next tone gate at the end of the preceding tone. If the 2nd tone is not accepted within approximately 120 ms, the counter is reset to standby, i. e. ready for the 1st tone.

The 2nd, 3rd, 4th, and 5th tone of a sequential signal are received as described for the 1st. When the 5th tone has been accepted information of the counter is read out to Latch U104b, which cancels the key and loudspeaker

blockings. At the same time the Call indicator is turned on, and the call may also cause an automatic transmission of receipt to take place, if used. The colour coded wires from the tone generator gates are soldered to the tone coil terminals, but if the same tone code is used for both tone transmitter and tone receiver, the code can be set by arranging the wires on the p. c. b. With the loudspeaker turned on depressing the Tone key button causes the following to take place:

A positive pulse from the Tone key button toggles the latch U104a whose Q and Q outputs control the internal switching from receive to transmit, and U104b controls the Transmitter Key switch and the Microphone Blocking.

When the clock generator U101c starts, the comparator U101a and the counter U103, are inhibited by the Q-output of U104a. The Q output enables the tone transmitter counter U102, inhibits the Clock Delay circuit, and turns on Q108 which increases the gain of the Q-multiplier Q107.

The clock generator pulses are applied to the counter U102, the repetition rate being 70 ms for TQ5001 and 100 ms for TQ5002. Upon arrival of the 3rd clock pulse the 1st tone gate transistor is turned on and the tone oscillator generates the 1st tone of the signal code. The oscillator output is passing an emitter-follower before being applied to the output terminal. The output voltage is adjustable by means of R113.

The 4th, 5th, 6th, and the 7th clockpulse successively turn on the remaining gate transistors to accomplish the signal code. The 8th clock pulse is used to introduce an interval before the 9th clock pulse resets the latch, U104a, and the TQ-unit reverts to the tone receive mode with the loudspeaker turned on.

PULSE-TIME DIAGRAM FOR 5-TONE SEQUENTIAL CALL TRANSMITTING IN TQ5001 AND TQ5002

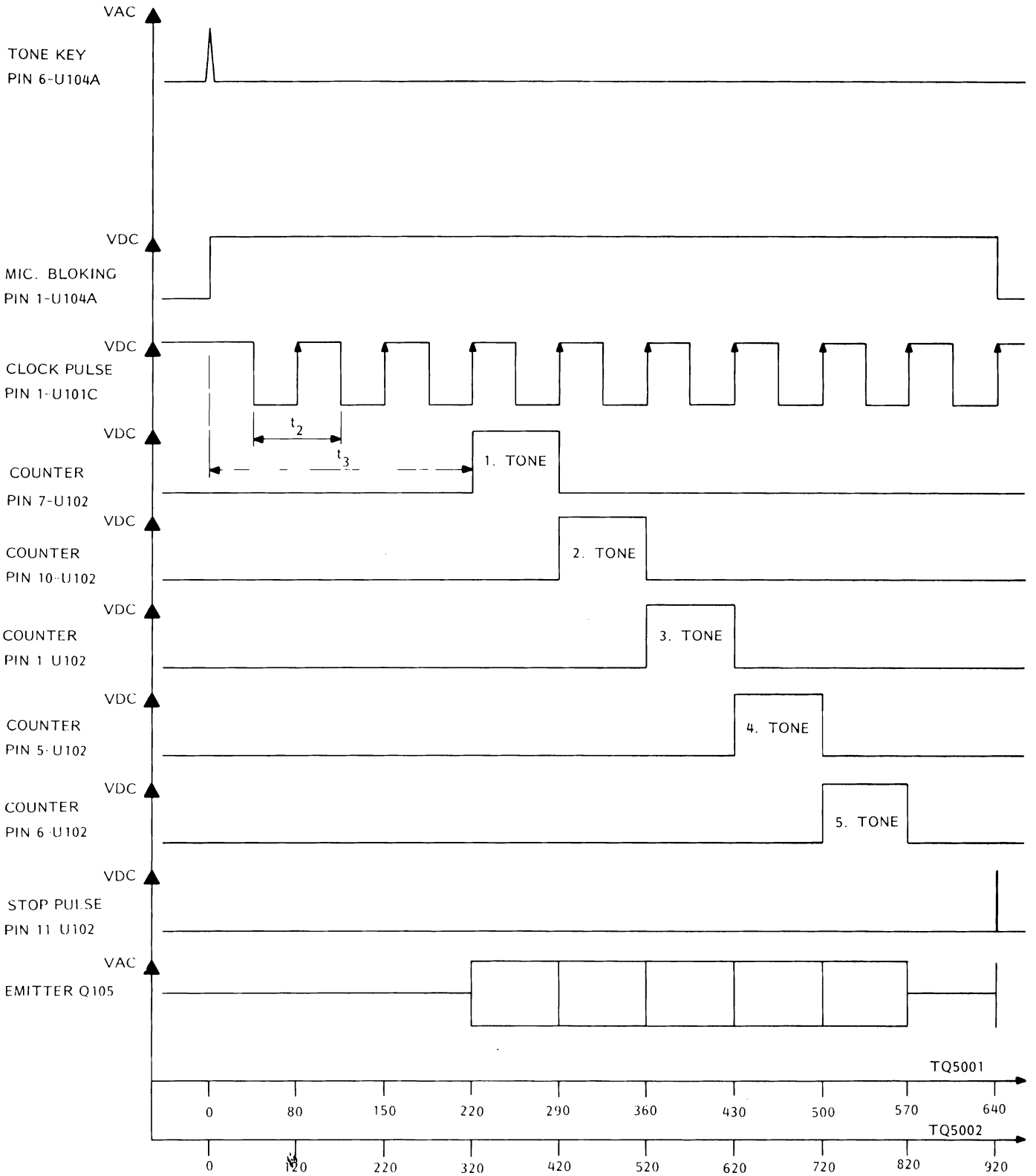

LOUDSPEAKER MANUALLY TURNED ON

- t_1 CHARGING TIME FOR CLOCK GENERATOR
- t_2 CLOCK PULSE PERIOD (TONE LENGTH)
- t_3 UNMODULATED PULSES BEFORE THE 1 ST TONE

PULSE-TIME DIAGRAM FOR 5-TONE AUTOMATIC RECEIPT

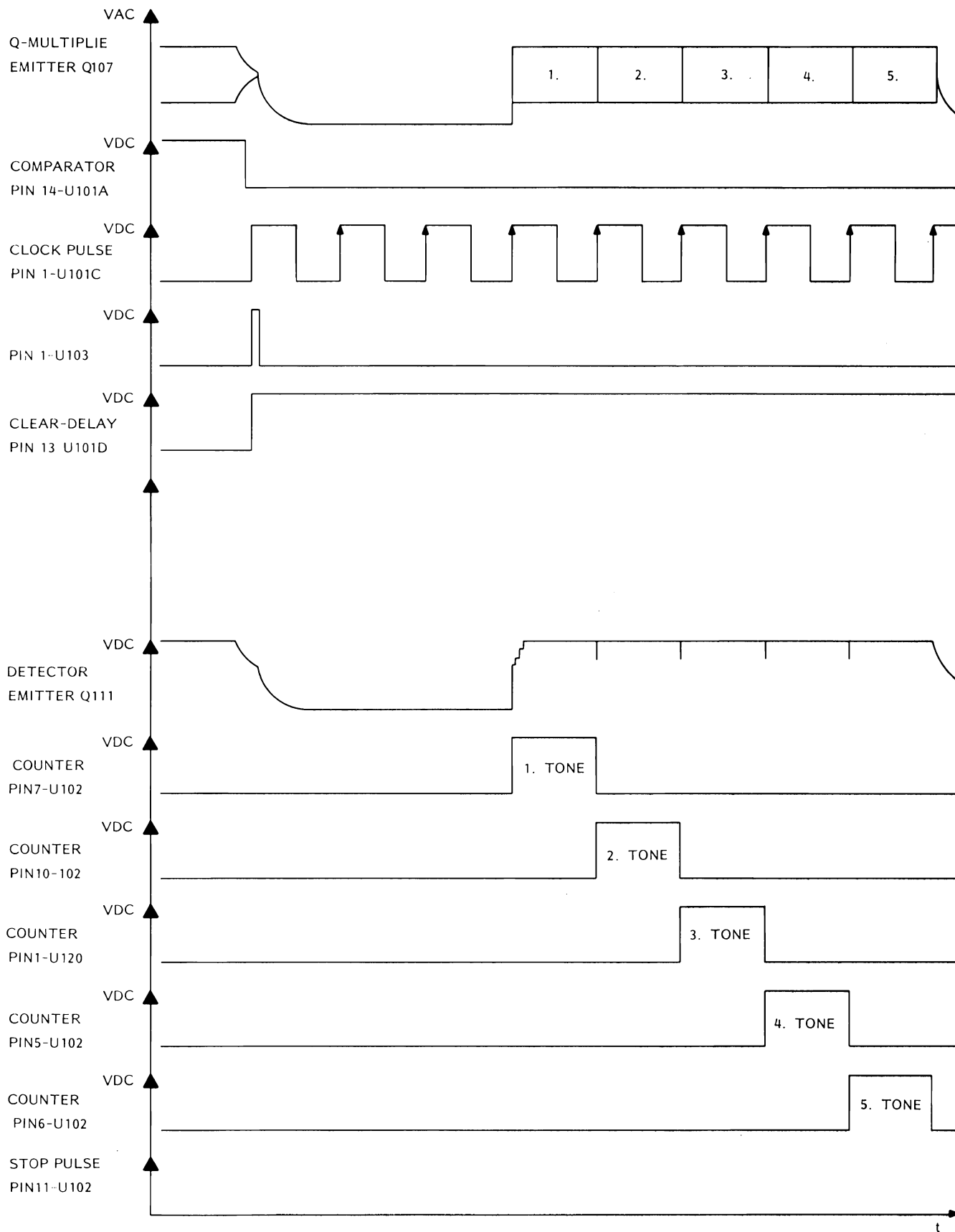

PULSE-TIME DIAGRAM FOR 5-TONE, SEQUENTIAL TONE RECEPTION IN TQ5001 AND TQ5002

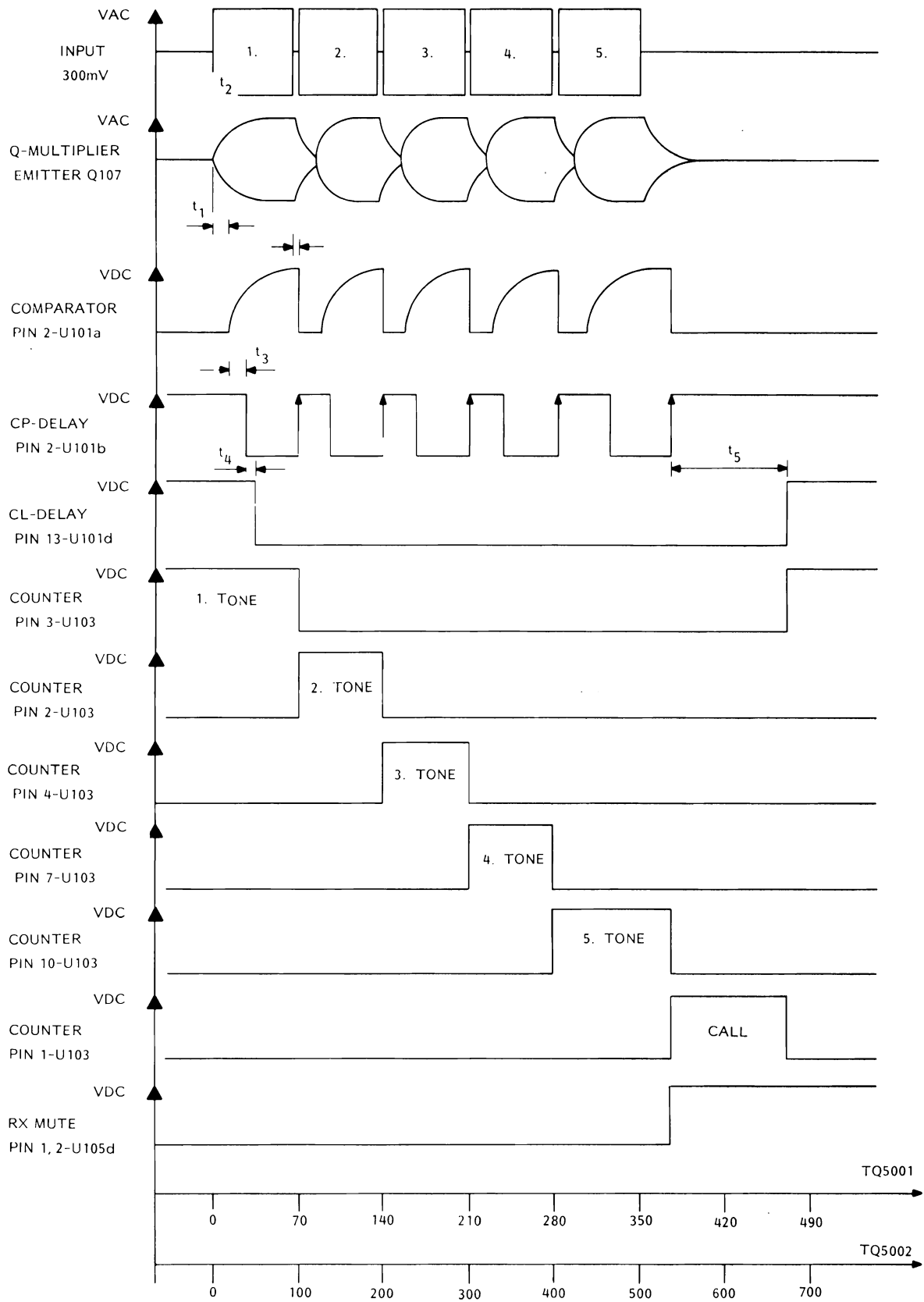

- t_1 . SELECTIVE CIRCUIT BUILD-UP TIME
- t_2 . DELAYTIME
- t_3 . CLOCK-DELAY
- t_4 . DELAY CHARGING TIME
- t_5 . CLEAR-DELAY

PULSE-TIME DIAGRAM FOR 5-TONE SEQUENTIAL CALL WITH GROUP CALL

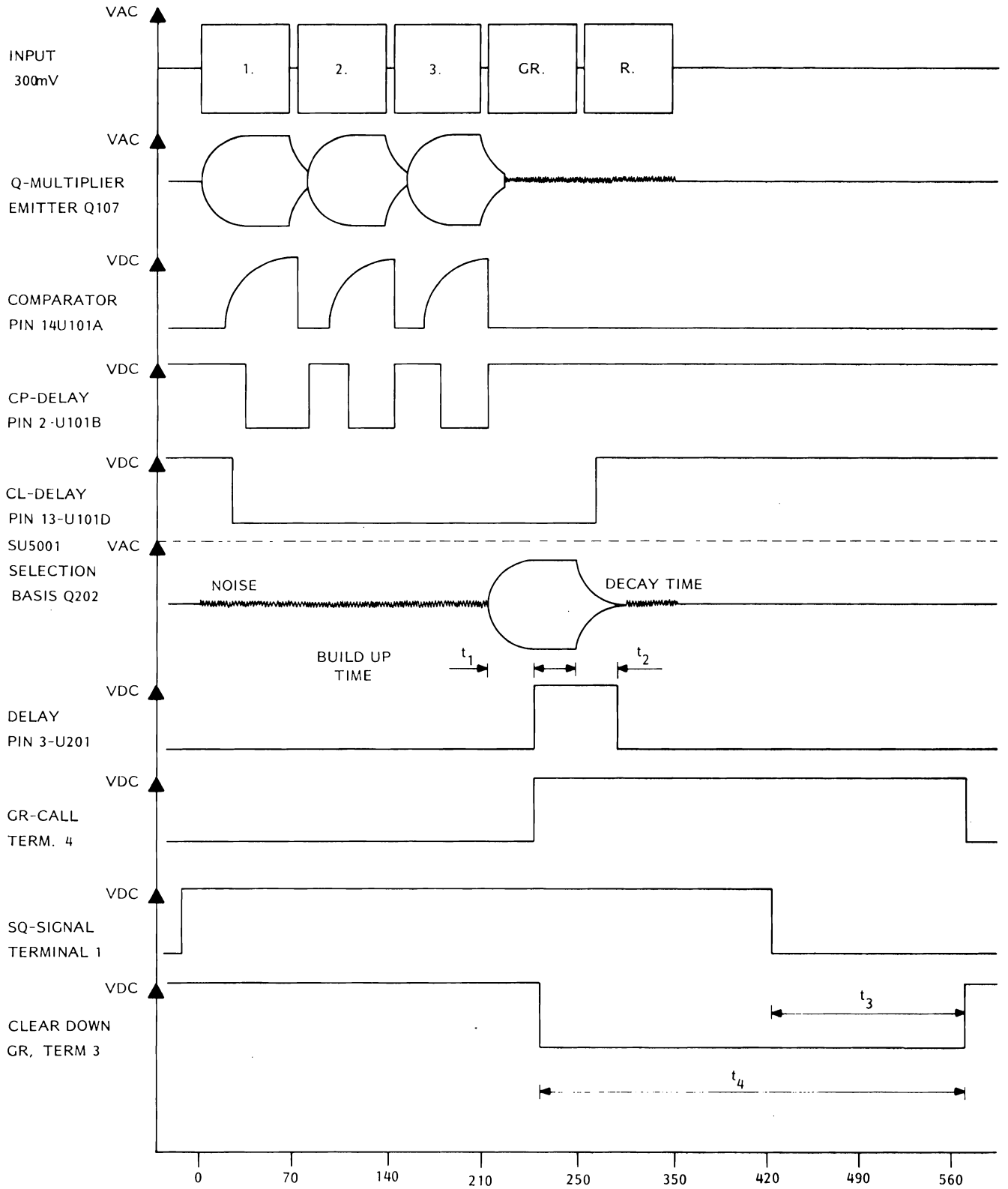

t_1 BUILD-UP TIME DELAY
 t_2 DELAY TIME HANGE TIME
 t_3 SQ-DELAY
 IN PERIOD t_4 THE AUTOMATIC RECEIPT TONE KEY AND LS IN OUT ARE INHIBITED.

CIRCUIT DESCRIPTION

INPUT AMPLIFIER AND LIMITER

Transistors Q101, Q102, and Q103 form a differential input amplifier/limiter, and Q104 is the resonant circuit driver. The received tone signal is amplified the gain being constant and determined by the ratio of R106 to R107. Signal levels higher than the minimum sensitivity (approx. 85 mV) will cause limiting, and the tone signal is then applied to the Group Call Unit SU5001, if any, (terminal 9) and to driver Q104. Transistor Q104 operates as current generator with its collector connected to a separate winding on the tone coil. The sensitivity and thus the sequential tone receiver bandwidth is adjustable with R111.

The amplifier is inhibited when depressing the Tone Key (and the normal Key) causing the 8.5 V TX to be applied to the base of Q101 through D101. Less than 100 ms after reverting from the tone transmitting mode the unit is ready to receive a call.

RESONANT CIRCUIT

The band pass filter consists of tone coil L101 and capacitor C113.

The signal from the input amplifier is coupled to the parallel resonant circuit via the coupling link. The colour coded wires from the tone gates switch the tone coil taps into the circuit in parallel with capacitor C113.

Q-MULTIPLIER, LIMITER REFERENCE VOLTAGE AND DETECTOR

These circuits consist of Q107, Q108, Q109, Q110, Q111, and their associated components. A part of the selected tone signal is fed via the Q-multiplier Q107 back to the coupling link and in phase with the input signal. This increases the bandpass filter Q-factor to approx. 30.

Resistors R123-R148 linearize this factor throughout the band, and the NTC resistor in the Q107 emitter compensates the Q-factor variations with ambient temperature.

The tone signal is rectified by transistor Q111 and the resultant d.c. voltage is applied to comparator U101a. Q108 is turned on by U104a when depressing the Tone Key, which increases the feedback so that the resonant circuit and Q107, which is the active component, form an oscillator. The signal voltage across the resonant circuit is amplitude limited by Q109 in order to obtain a constant signal output level from the oscillator and to reduce the decay time for strong signals. The gate transistor bias and the detector bias voltages are derived from Q110.

OUTPUT EMITTER FOLLOWER AND CLIPPER

The desired frequency characteristic is flat because the tone signal is connected directly to the splatter-filter. The output stage consists of the emitter follower Q105, and R113 is generator impedance for the OP-Amp of the splatterfilter. Due to the DC-shift in the oscillator a peak will appear at the start, and the end of the tone signal, but this peak will be limited by Q106.

COMPARATOR

The comparator is build around U101a, whose trigger reference level is determined by voltage divider R130-R131/R181 and controlled by the Q-output of latch U104a. The rectified tone signal increases the d.c. voltage to the non-inverting input of the comparator and when the level exceeds the reference voltage, the output of U101a will change from being a short to ground, to be the off state. This state persists for a time determined by the length of the tone. After the tone period the output will revert to form a ground path.

When depressing the Tone Key, U101a is inhibited in its standby state by the Q-output of U104a.

CLOCK-DELAY AND CLOCK GENERATOR

The Clock-delay is determined by R132 and C107. In standby the charge of capacitor C107 is neutral due to the discharge through the output of U101a, and the clock generator U101c is inhibited in its off position. The reference voltage, which is common to U101b and U101c, is, via voltage divider R133, R134, R135, applied to their non-inverting inputs. When the comparator U101a is activated, the voltage across C107 will start to go positive. After 17 ms (Clock-delay) the Schmitt trigger U101b will be activated and the output voltage will drop to 0 V. At the end of the tone C107 again discharges via U101a.

This produces a positive going voltage edge at the U101b output which is applied to the clock inputs of counters U102 and U103 whose outputs switch the circuits to the next tone gate. If the comparator detects a new tone the procedure is repeated as previously described.

The comparator will, in its inhibited state (TONE KEY activated), keep U101b off. On the other hand, the clock generator U101c is released by biasing D104 off. C108 is charged through resistors R136, R137, and R138 until reaching the common reference voltage, and the output of U101c drops to 0V. This d. c. voltage transition is via R134 fed back to the non-inverting input and thus causes a hysteresis. C108 is discharged to the lower voltage level and the positive edge so created is used as clock input to counter U102. The period time is adjusted by means of resistor, R137, to 70ms (TQ5001) or 100 ms for TQ5002.

CLEAR DELAY

Comparator U101d is controlled by the Schmitt trigger U101b. In standby the charge of C109 is neutral because D103 is reverse biased.

The output level of U101d corresponds to the supply voltage, 8.5 V, and counter U103 is cleared and set to the 1st tone gate. Triggering U101b enables C109 to be charged of via D103 and R140, and when the voltage of C109 has fallen to the reference level, U101d changes its output to 0 V and releases counter 103 which now is ready to receive the clock pulses.

The U101d reference level is controlled by U104a's \bar{Q} -output which in standby is approximately 8.5 V. Depressing the Tone Key button causes the reference level to fall to 0 V and U101d is blocked in its standby position, and hence counter U103 is blocked accordingly. As long as the Schmitt trigger, U101b, is active, D103 will maintain the charge of C109. When the last tone ceases, U101b reverts to standby and D103 is reverse biased. The discharge of C109 is determined by R139 and R140 which within approximately 120 ms reduces the charge of the capacitor until it corresponds to the reference level.

The U101d output voltage returns to 8.5 V and clears the counter, U103, after which the 1st tone gate is reengaged, and the tone receiver is ready to receive a new call. As the intervals between the individual tones in sequential tone call are far less than the above mentioned 120ms, the clear delay will retain its state for this period.

COUNTER AND TONE GATES

Two decimal counters are employed as tone generator pulse counter (U102) and tone receiver pulse counter, (U103). The counter outputs control the tone gates, Q112-121.

Determined by the clock generator period, counter U102's outputs will, consequently, open gate transistors Q112 to Q116 the collectors of which are tied to the tone coil taps and so producing the tones of the sequential tone signal. The first gate transistor is connected to the fourth counter output for which reason a period of 220 ms for TQ5001, and 320 ms for TQ5002 elapses -corresponding to the three first clock pulses- before generation of the 1st tone is started.

The time following the 9th clock pulse is utilized to discharge detector Q111, and the 10th clock pulse is fed, via R154, to latch U104a as a "stop" information. In order to hold the gate transistors effectively cut off their emitters are biased at 4.1 V.

The clear input of U102 is controlled by U104a's \bar{Q} -output, and therefore the counter is inhibited in standby and is not released until the Tone Key button is depressed. Counter U103 opens the tone receiver gate transistors, Q117-Q121.

The control signals for the counter is derived from U101b and the clear delay U101d, respectively.

In standby the counter is inhibited by U101d and the 1st tone gate is opened by the "0" output. The mode of operation for counter U103 is similar to that of U102 the clock pulse period corresponding to the received tone pulse lengths.

Approximately 120ms after the cessation of the last tone the counter is reset to standby by U101d. All counter outputs of U103 are accessible on the p. c. b. for setting the individual and the group call combinations (see instructions for coding and strapping).

Transistor Q122 is, together with the counter enable input, controlled by U104a's Q-output, which in standby is 0 V. Depressing the Tone Key button blocks the U103 clock input, and at the same time the 1st tone gate is blocked by Q122.

The elapse of time to transmit, or receive, a 5-tone sequential signal appears from the time-pulse diagrams.

LATCH, LS IN/OUT, TONE KEY AND FLASHING CIRCUIT

As latch for the tone receiver and tone transmitter functions, a dual-D-flip-flop U104 is employed of which U104a is directly controlled by U104b via diodes D105 and D106. An R-S flip-flop, U105a-U105b, prevents contact bounce in the LS in/out button from operating the latch.

After a tone call, or after having opened the loudspeaker manually the flashing circuit, U106 with its associated components will start flashing the yellow LED Call indicator (D107).

When applying the supply voltage, 8.5 V CONT U104b is forced into state "LS out" by the positive pulse fed to the latch reset input via C115. The call pulse is derived from one of counter U103's outputs and applied to U104b's set input and, according to note 6 on the diagram, to U104a as a receipt pulse. After a received tone call, U104b remains in state "LS in" until manually reset by depressing the LS in/out button. The tone transmitter latch, U104a, is inhibited in standby via diode D106 and, accordingly, the information from the Tone Key input terminal is short circuited via D105.

To perform a tone call U104b must be toggled manually to reverse bias D105 and D106 (or by a received tone call).

MUTE AND ALARM

The mute function takes the information from the Q output of U104b and turns Q124 ON after a call or a manual opening of the loudspeaker.

The Alarm (Q123) is ON for a short time (70 ms) immediately after the 5th tone.

PTT (TO RELAY) AND PTT (PUSH TO TALK)

When pressing the Tone Key, Q125 will go on and operate the transmitter relay. Q125/126 are controlled by the \bar{Q} output of U104a which is triggered by U105c.

The normal keying of the RF transmitter is achieved by shorting terminal 3 to ground, but if the tone receiver is not opened, Q127 is off, and hence it prevents the transmitter from being keyed.

MICROPHONE BLOCKING AND RX MUTE

When the transmitter is keyed, the microphone amplifier supply comes via Q129.

When "Tone Key" is activated, U104a blocks Q129, the microphone is deprived of its supply, and the amplifier blocked.

After reception of a correct call, or manual opening, Q130 switches off and cancels the clamping of the RX mute lead, so that only the noise controlled squelch circuit decides whether the sets audio channel should be open or not.

TECHNICAL SPECIFICATIONS TQ5001.

Supply Voltage

8.5 V \pm 0.25 V (Cont. and TX)

Current Drain

Standby

<20 mA

Engaged

20 mA +25 mA peak when call indicator is on

Temperature Range

-30°C to +60°C.

SEQUENTIAL TONE TRANSMITTER

Output Impedance

50 Kohm max.

Output Signal

3, 4 or 5 tones in burst of 70 ms \pm 15 ms.

The interval between triggering and emission of the 1st tone is min. 200 ms.

Signal output level

600 mV emf. max.

Frequency response

Flat. \pm 1 dB

Distortion

max. 5%

Tone frequencies

885, 970, 1060, 1160, 1270, 1400, 1530, 1670, 1830, 2000, 2200, 2400, 2600, 2800 Hz.

Frequency accuracy

Typical deviation (28)

1%

Maximum deviation

1.4%

Relative frequency accuracy

0.3%

Adjustment accuracy

0.1%

Frequency stability

1%

CONTROL FUNCTIONS

Receipt

TQ5001 can be strapped to automatic transmission of receipt after a received sequential call.

Automatic Keying

TQ5001 energizes the transmitter for approx. 640 ms.

Microphone inhibit

The voltage supply to the microphone amplifier is inhibited during the tone key.

SEQUENTIAL TONE RECEIVER

Input impedance

>30 Kohm, DC isolation

Input Response

De-emphasis according to an RC-function with
F_c= 2900 Hz.

Signalling code

3. 4 or 5 tone burst of min

55 ms duration.

Activating Level

300 mV ± 6 dB

Distortion

The TQ5001 can process tone signals having less than 20% distortion.

Tone Frequencies

885, 970, 1060, 1160, 1270, 1400, 1530, 1670,
1830, 2000, 2200, 2400, 2600, 2800 Hz.

Frequency Accuracy

± 0.3%

Selectivity

The tone receiver responds to tones with a frequency deviation less than 1.4%. The tone receiver is not sensitive to adjacent tones or other tones of the same standard series.

Reset Time

minimum 90 ms

maximum 140 ms

Reaction Time

minimum 20 ms

maximum 45 ms

Signal to Noise Conditions

The tone receiver will accept a noise level corresponding to SINAD= 5 dB as measured in the speech channel of the CQM5000.

TECHNICAL SPECIFICATIONS TQ5002

Supply Voltage

8.5V ± 0.25 V (Cont and TX)

Current Drain

Standby

<20 mA

Engaged

20 mA +25 mA peak when call indicator is on.

Temperature Range

-30°C to +60°C

SEQUENTIAL TONE TRANSMITTER

Output Impedance

50 Kohm max.

Output Signal

3.4 or 5 tones in burst of 100 ms ± 15 ms.

The interval between triggering and emission of the 1st tone is min 300 ms.

Signal output level

600 mV emf. max.

Frequency response

Flat. ± 1 dB

Distortion

max. 5%

Tone frequencies

(960, 1022), 1124, 1197, 1275, 1358, 1446, 1540,
1640, 1747, 1860, 1981, 2110 Hz.

Frequency accuracy

Typical deviation (2 δ)

1%

Maximum deviation

1.4%

Relative frequency accuracy

0.3%

Adjustment accuracy

0.1%

Frequency stability

1%

CONTROL FUNCTIONS

Receipt

TQ5002 can be strapped to automatic transmission of receipt after a received sequential call.

Automatic Keying

TQ5002 energizes the transmitter for approx. 900 ms.

Microphone inhibit

The voltage supply to the microphone amplifier is inhibited during the tone key.

SEQUENTIAL TONE RECEIVER

Input impedance

>30 Kohm, DC isolation

Input Response

De-emphasis according to an RC-function with $F_c = 2900$ Hz.

Signalling code

3, 4 or 5 tone burst of min. 55 ms duration.

Activating Level

300 mV \pm 6 dB

Distortion

The TQ5002 can process tone signals having less than 20% distortion.

Tone Frequencies

(960, 1022), 1124, 1197, 1275, 1358, 1446, 1540, 1640, 1747, 1860, 1981, 2110 Hz.

Frequency Accuracy

\pm 0.3%

Selectivity

The tone receiver responds to tones with a frequency deviation less than 1.4%. The tone receiver is not sensitive to adjacent tones or other tones of the same standard series.

Reset Time

minimum 90 ms

maximum 140 ms

Reaction Time

minimum 20 ms

maximum 45 ms

Signal to Noise Conditions

The tone receiver will accept a noise level corresponding to SINAD= 5 dB as measured in the speech channel of the CQM5000.

OUTPUT FUNCTIONS

A sequence call produces the following output signals.

Green L. E. D. will start flashing, cancel the short-circuit of terminal 4, and short-circuit 2-3.

Manual activation of LS in/out

establishes the output functions as above.

Switching the LS off

produces the following output signals.

The L. E. D. will stop flashing.

Key Blocking:

The connection between terminal 2 and 3 will be cancelled.

Audio Blocking:

Short-circuits terminal 4 to ground.

Length

159.8 mm.

Width

69 mm

Weight

86 g.

TONE OUTPUT

VOL /50 HI

+85V CONT.

+85V TX

ALARM

-A

MUTE

LS IN/OUT

TONE KEY

TONE KEY

PTT (TO RELAY)

PTT

MIC BLOCK

RX MUTE

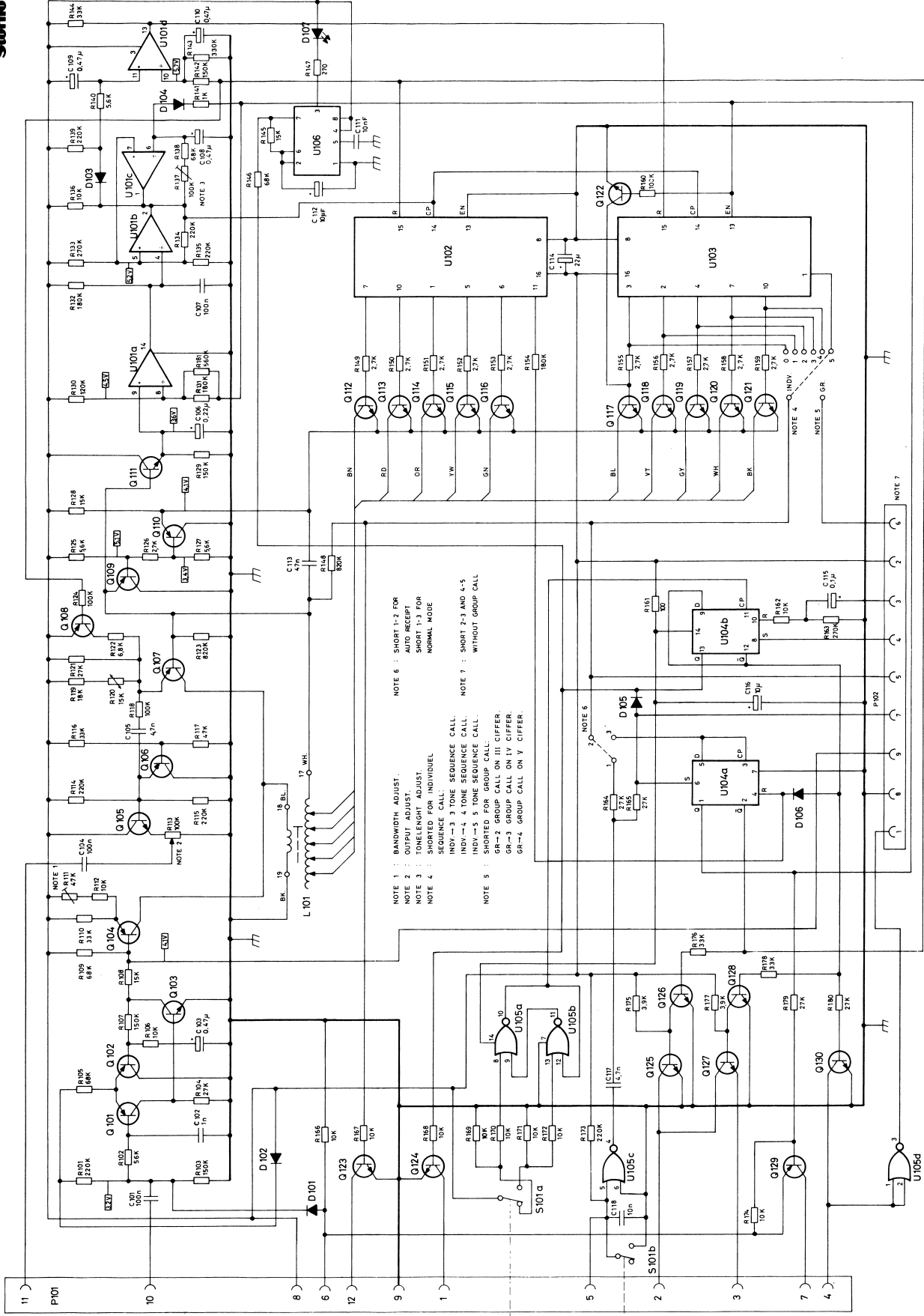

- NOTE 1 : BANDWIDTH ADJUST.
- NOTE 2 : OUTPUT ADJUST.
- NOTE 3 : TONELENGTH ADJUST.
- NOTE 4 : SHORTED FOR INDIVIDUAL SEQUENCE CALL.
- NOTE 5 : SHORT 2-3 AND 4-5 INDY-4 4 TONE SEQUENCE CALL. INDY-5 5 TONE SEQUENCE CALL. INDY-6 6 TONE SEQUENCE CALL. GR-1 GROUP CALL ON IV CIPHER. GR-2 GROUP CALL ON IV CIPHER. GR-3 GROUP CALL ON IV CIPHER. GR-4 GROUP CALL ON V CIPHER.
- NOTE 6 : SHORT 1-2 FOR AUTO RECEPT SHORT 1-3 FOR NORMAL MODE.
- NOTE 7 : SHORT 2-3 AND 4-5 WITHOUT GROUP CALL.

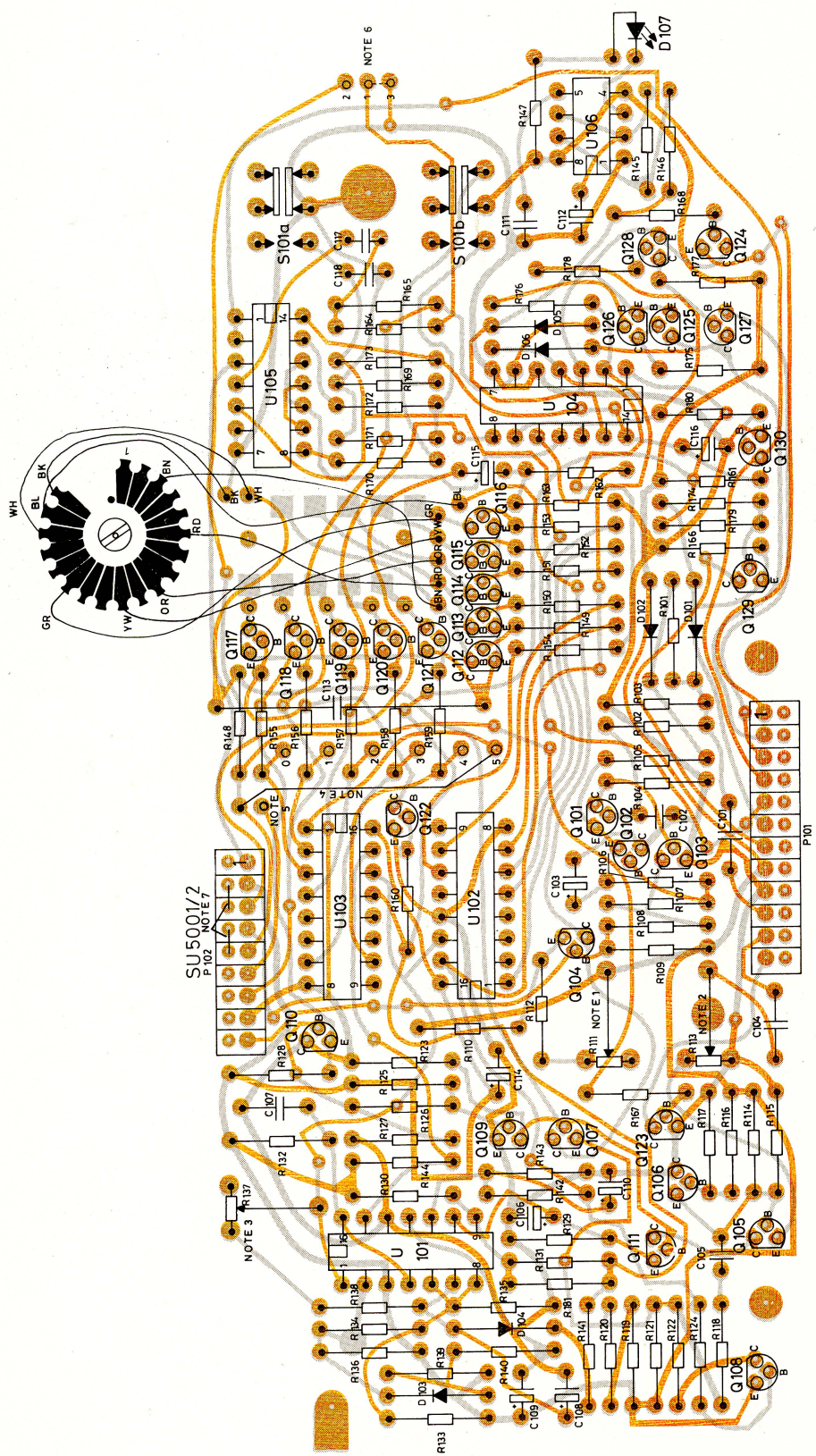

SEQUENTIAL TONE UNIT
 COMPONENT LAYOUT
 TQ 5001, TQ5002

D402.622/2

COIL TERM	DIGIT	TQ5001 STORNO FREQ	TQ5002 CCIR FREQ
1	X	885 Hz	960 Hz
2	Y	970 Hz	1062 Hz
3	1	1060 Hz	1124 Hz
4	2	1160 Hz	1197 Hz
5	3	1270 Hz	1275 Hz
6	4	1400 Hz	1358 Hz
7	5	1530 Hz	1446 Hz
8	6	1670 Hz	1540 Hz
9	7	1830 Hz	1640 Hz
10	8	2000 Hz	1747 Hz
11	9	2200 Hz	1860 Hz
12	0	2400 Hz	1981 Hz
13	R	2600 Hz	2110 Hz
14	A	2800 Hz	-

TYPE	Nº	CODE	DATA
	Q118	99. 5324	BC338-25 Transistor
	Q119	99. 5324	BC338-25 Transistor
	Q120	99. 5324	BC338-25 Transistor
	Q121	99. 5324	BC338-25 Transistor
	Q122	99. 5143	BC238 Transistor
	Q123	99. 5143	BC238 Transistor
	Q124	99. 5143	BC238 Transistor
	Q125	99. 5143	BC238 Transistor
	Q126	99. 5143	BC238 Transistor
	Q127	99. 5143	BC238 Transistor
	Q128	99. 5143	BC238 Transistor
	Q129	99. 5230	BC308 Transistor
	Q130	99. 5143	BC238 Transistor
	R101	80. 5277	220 Kohm 5% Carbon film
	R102	80. 5270	56 Kohm 5% Carbon film
	R103	80. 5275	150 Kohm 5% Carbon film
	R104	80. 5266	27 Kohm 5% Carbon film
	R105	80. 5271	68 Kohm 5% Carbon film
	R106	80. 5261	10Kohm 5% Carbon film
	R107	80. 5275	150 Kohm 5% Carbon film
	R108	82. 5263	15 Kohm 5% Carbon film
	R109	80. 5271	68 Kohm 5% Carbon film
	R110	80. 5267	33 Kohm 5% Carbon film
	R111	86. 5036	47 Kohm 20% Carbon pot.
	R112	80. 5261	10 Kohm 5% Carbon film
	R113	86. 5074	100 Kohm 20% Carbon pot.
	R114	80. 5277	220 Kohm 5% Carbon film
	R115	80. 5277	220 Kohm 5% Carbon film
	R116	80. 5267	33 Kohm 5% Carbon film
	R117	80. 5269	47 Kohm 5% Carbon film
	R118	80. 5273	100 Kohm 5% Carbon film
	R119	80. 5264	18 Kohm 5% Carbon film
	R120	89. 5010	15 Kohm 20% NTC
	R121	80. 5266	27 Kohm 5% Carbon film
	R122	80. 5259	6.8 Kohm 5% Carbon film
	R123	80. 5284	820 Kohm 5% Carbon film
	R124	80. 5273	100 Kohm 5% Carbon film
	R125	80. 5258	5.6 Kohm 5% Carbon film
	R126	80. 5254	2.7 Kohm 5% Carbon film
	R127	80. 5258	5.6 Kohm 5% Carbon film
	R128	80. 5263	15 Kohm 5% Carbon film
	R129	80. 5275	150 Kohm 5% Carbon film

**SEQUENTIAL TONE UNIT TQ5001
SEQUENTIAL TONE UNIT TQ5002**

X402. 645/3

TYPE	Nº	CODE	DATA
	C101	76. 5144	0. 1 uF 10% Polyest. FL
	C102	76. 5129	1 nF 10% Polyest. FL
	C103	73. 5169	0. 47 uF 20% Tantal
	C104	76. 5144	0. 1 uF 10% Polyest. FL
	C105	76. 5133	4. 7 nF 10% Polyest. FL
	C106	73. 5168	0. 22 uF 20% Tantal
	C107	76. 5144	0. 1 uF 10% Polyest. FL
	C108	73. 5169	0. 47 uF 20% Tantal
	C109	73. 5169	0. 47 uF 20% Tantal
	C110	73. 5169	0. 47 uF 20% Tantal
	C111	76. 5135	10 nF 10% Polyest. FL
	C112	73. 5173	10 uF 20% Tantal
	C113	76. 5123	47 nF 25% Polyest. TB
	C114	73. 5174	22 uF 20% Tantal
	C115	73. 5167	0. 1 uF 20% Tantal
	C116	73. 5173	10 uF 20% Tantal
	C117	76. 5133	4. 7 nF 10% Polyest. FL
	C118	76. 5135	10 nF 10% Polyest. FL
	D101	99. 5237	1N4148 Diode
	D102	99. 5237	1N4148 Diode
	D103	99. 5237	1N4148 Diode
	D104	99. 5237	1N4148 Diode
	D105	99. 5237	1N4148 Diode
	D106	99. 5237	1N4148 Diode
	D107	99. 5325	LED Yellow
TQ5001	L1	61. 1337	Tone coil
TQ5002	L1	61. 1366	Tone coil
	P101	41. 5549	Fem. Connector
	P102	41. 5548	Fem. Connector
	Q101	99. 5230	BC308 Transistor
	Q102	99. 5230	BC308 Transistor
	Q103	99. 5143	BC238 Transistor
	Q104	99. 5230	BC308 Transistor
	Q105	99. 5143	BC238 Transistor
	Q106	99. 5230	BC308 Transistor
	Q107	99. 5115	BC309 Transistor
	Q108	99. 5230	BC308 Transistor
	Q109	99. 5230	BC308 Transistor
	Q110	99. 5230	BC308 Transistor
	Q111	99. 5143	BC238 Transistor
	Q112	99. 5324	BC338-25 Transistor
	Q113	99. 5324	BC338-25 Transistor
	Q114	99. 5324	BC338-25 Transistor
	Q115	99. 5324	BC338-25 Transistor
	Q116	99. 5324	BC338-25 Transistor
	Q117	99. 5324	BC338-25 Transistor

2 PIN

9 PIN

TYPE	Nº	CODE	DATA
	R130	80. 5274	120 Kohm 5% Carbon film 0. 125 W
	R131	80. 5276	180 Kohm 5% Carbon film 0. 125 W
	R132	80. 5276	180 Kohm 5% Carbon film 0. 125 W
	R133	80. 5278	270 Kohm 5% Carbon film 0. 125 W
	R134	80. 5277	220 Kohm 5% Carbon film 0. 125 W
	R135	80. 5277	220 Kohm 5% Carbon film 0. 125 W
	R136	80. 5261	10 Kohm 5% Carbon film 0. 125 W
	R137	86. 5074	100 Kohm 20% Carbon pot. 0. 1 W
	R138	80. 5271	68 Kohm 5% Carbon film 0. 125 W
	R139	80. 5277	220 Kohm 5% Carbon film 0. 125 W
	R140	80. 5258	5. 6 Kohm 5% Carbon film 0. 125 W
	R141	80. 5249	1 Kohm 5% Carbon film 0. 125 W
	R142	80. 5275	150 Kohm 5% Carbon film 0. 125 W
	R143	80. 5279	330 Kohm 5% Carbon film 0. 125 W
	R144	80. 5267	33 Kohm 5% Carbon film 0. 125 W
	R145	82. 5263	15 Kohm 5% Carbon film 0. 125 W
	R146	80. 5271	68 Kohm 5% Carbon film 0. 125 W
	R147	80. 5243	270 ohm 5% Carbon film 0. 125 W
	R148	80. 5284	820 Kohm 5% Carbon film 0. 125 W
	R149	80. 5254	2. 7 Kohm 5% Carbon film 0. 125 W
	R150	80. 5254	2. 7 Kohm 5% Carbon film 0. 125 W
	R151	80. 5254	2. 7 Kohm 5% Carbon film 0. 125 W
	R152	80. 5254	2. 7 Kohm 5% Carbon film 0. 125 W
	R153	80. 5254	2. 7 Kohm 5% Carbon film 0. 125 W
	R154	80. 5276	180 Kohm 5% Carbon film 0. 125 W
	R155	80. 5254	2. 7 Kohm 5% Carbon film 0. 125 W
	R156	80. 5254	2. 7 Kohm 5% Carbon film 0. 125 W
	R157	80. 5254	2. 7 Kohm 5% Carbon film 0. 125 W
	R158	80. 5254	2. 7 Kohm 5% Carbon film 0. 125 W
	R159	80. 5254	2. 7 Kohm 5% Carbon film 0. 125 W
	R160	80. 5273	100 Kohm 5% Carbon film 0. 125 W
	R161	80. 5237	10 ohm 5% Carbon film 0. 125 W
	R162	80. 5261	10 Kohm 5% Carbon film 0. 125 W
	R163	80. 5278	270 Kohm 5% Carbon film 0. 125 W
	R164	80. 5266	27 Kohm 5% Carbon film 0. 125 W
	R165	80. 5266	27 Kohm 5% Carbon film 0. 125 W
	R166	80. 5261	10 Kohm 5% Carbon film 0. 125 W
	R167	80. 5261	10 Kohm 5% Carbon film 0. 125 W
	R168	80. 5261	10 Kohm 5% Carbon film 0. 125 W
	R169	80. 5261	10 Kohm 5% Carbon film 0. 125 W
	R170	80. 5261	10 Kohm 5% Carbon film 0. 125 W
	R171	80. 5261	10 Kohm 5% Carbon film 0. 125 W
	R172	80. 5261	10 Kohm 5% Carbon film 0. 125 W
	R173	80. 5277	220 Kohm 5% Carbon film 0. 125 W
	R174	80. 5261	10 Kohm 5% Carbon film 0. 125 W
	R175	80. 5256	3. 9 Kohm 5% Carbon film 0. 125 W
	R176	80. 5267	33 Kohm 5% Carbon film 0. 125 W

TYPE	Nº	CODE	DATA
	R177	80. 5256	3. 9 Kohm 5% Carbon film 0. 125 W
	R178	80. 5267	33 Kohm 5% Carbon film 0. 125 W
	R179	80. 5266	27 Kohm 5% Carbon film 0. 125 W
	R180	80. 5266	27 Kohm 5% Carbon film 0. 125 W
	R181	80. 5281	560 Kohm 5% Carbon film 0. 125 W
	S101	47. 0642	Switch
	U101	14. 5019	MC3302 Quad. Comparat.
	U102	14. 5052	4017 Johnson Counter
	U103	14. 5052	4017 Johnson Counter
	U104	14. 5098	4013 Dual D-FF
	U105	14. 5074	4001 Quad. 2-inp. NAND
	U106	14. 5134	555 Timer

SEQUENTIAL TONE UNIT TQ5001
SEQUENTIAL TONE UNIT TQ5002

X402_645/2

CODING AND STRAPPING OF TQ5001 AND TQ5002

The sequential tone transmitter and sequential tone receiver codes are independent of each other for which reason examples are given separately. See notes on the schematic diagram.

The sequential tone receiver is capable of receiving 3, 4 or 5 tones in a decadic system in which each digit is represented by a specific tone. Group call codings are described later, refer to SU5001 and SU5002.

Sequential Tone receiver, individual call.

Strapping for 3, 4 or 5 tone sequential call

For receiving and transmitting 3, 4 or 5 tones connect a wire from Note 4 to the terminal with the desired number. (Note 4 = INDV)

See fig. 1

The wire colors indicate the order of the tonegates, BN, RD, OR, YW, and GN for the sequential tone transmitter code, BL, VT, GY, WH and BK for the sequential tone receiver code. Each wire soldered to the tone coil represents one digit of the call number. If

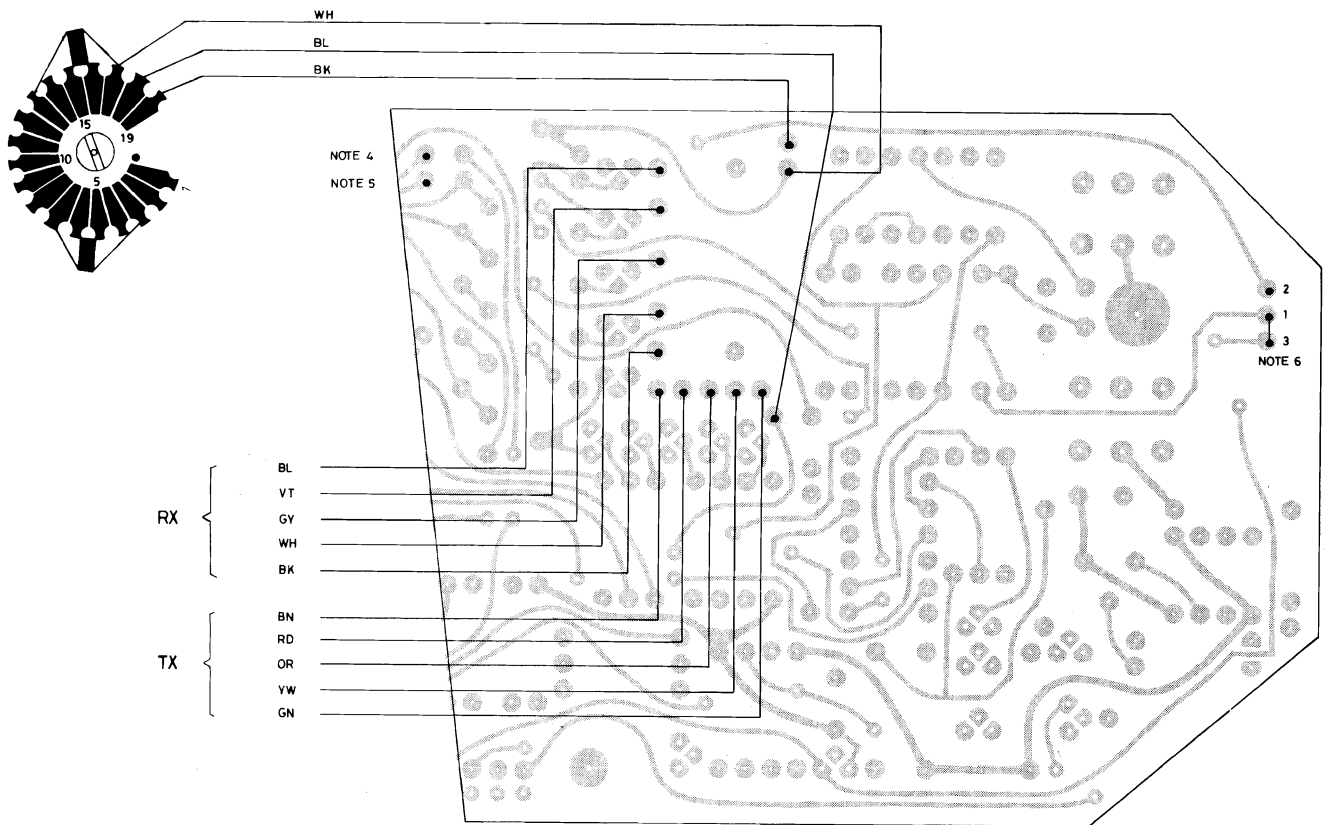

Fig. 1

Viewed from component side

the actual call number contains two identical digits following each other, a repeat tone is used for the latter. The procedure is repeated if more than 2 identical digits are used.

As an example the number 33333 is coded 3R3R3.

		5-tone call	4-tone call	3-tone call
Blue wire	1st tone	1st digit	1st digit	1st digit
Violet wire	2nd tone	2nd digit	2nd digit	2nd digit
Gray wire	3rd tone	3rd digit	3rd digit	3rd digit
White wire	4th tone	4th digit	4th digit	3rd digit
Black wire	5th tone	5th digit	4th digit	3rd digit

When coding 3-tone calls and 4-tone calls the remaining wires are, on the p. c. b., connected, to the last digit.

If the tone transmitter code and the tone receiver code are identical, the tone

gate wires may be interconnected on the p. c. b. as shown:

Tone transmitter code: 23354 (23R54)

Tone receiver code: 23354

See Fig. 2.

Part of printed circuit

Coil on component side

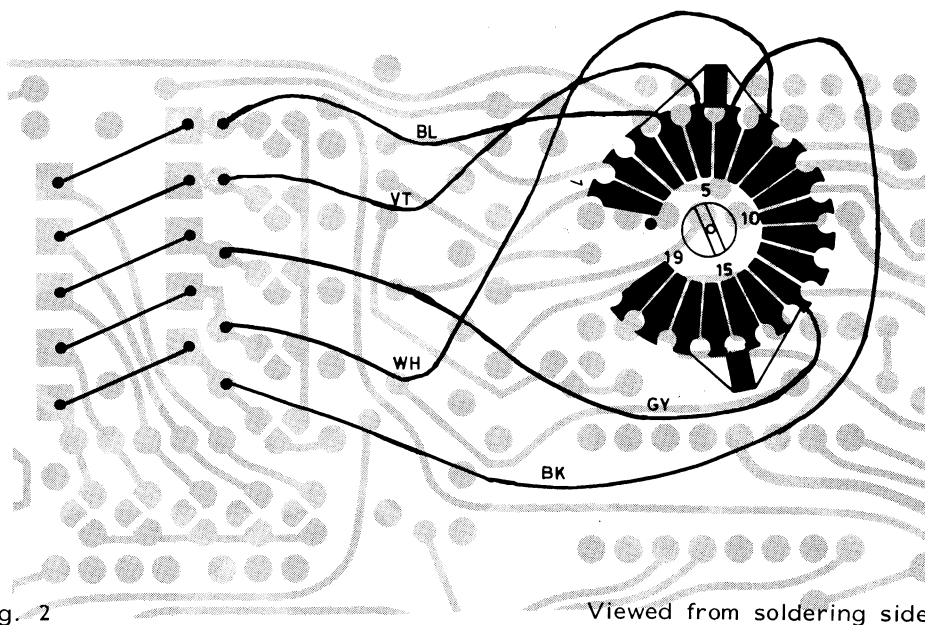

Fig. 2

Viewed from soldering side

Group digit coding

The TQ-unit can be installed together with a group call unit SU5001 or an all-call unit SU5002, designed for group calls or all-calls with 1 digit. A connection between terminal GR (NOTES) and terminal 2, 3, or 4 are for group calls with 1 group call tone on the 3rd tone, the 4th tone, or the 5th tone.

A connection between terminal GR (NOTE5) and terminal 0 are for All-Call.

For code combinations and their limitations see coding of SU5001 and SU5002.

Auto Receipt

See NOTE 6 and Fig. 1.

Tone coil

Terminal numbers on the tone coil tags and their relating digits and frequencies appear from the table.

Terminal	Digit	STORNO. ZVEI Frequency, Hz	CCIR Frequency Hz
1	X	885	960
2	Y	970	1062
3	1	1060	1124
4	2	1160	1197
5	3	1270	1275
6	4	1400	1358
7	5	1530	1446
8	6	1670	1540
9	7	1830	1640
10	8	2000	1747
11	9	2200	1860
12	0	2400	1981
13	R	2600	2110
14	A	2800	

R =Repeat tone

A = Alarm tone

X and Y: Special tones, used for A and R in 12, 5kHz channel spacing equipment.

CHANNEL GUARD UNIT

TQ5003 - TT5001 - TR5001 - FN5001

GENERAL

The Channel Guard (Pilot Tone) module is a continuous tone encoder/decoder for operation on tone frequencies in the 71.9 Hz to 210.7 Hz range. The encoder provides tone-coded modulation to the transmitter and the decoder operates in conjunction with the receiver to inhibit all calls that are not tone-coded with the proper Channel Guard frequency.

Four versions of the Channel Guard module are available:

- TQ5003 Single tone encode/decode
- TR5001 Single tone decode only
- TT5001 Single tone encode only
- FN5001 Single tone reject filter

The Channel Guard circuitry consists of discrete components for the Encode disable, PTT switch, and receiver mute switch; four thick-film integrated circuit modules consisting of Decode Module U1001, Encode Module U1002, Frequency Switchable Selective Amplifier (FSSA) AR1001, and plug-in Versatone Network FL1001 and monolithic IC U1003 in the tone reject filter.

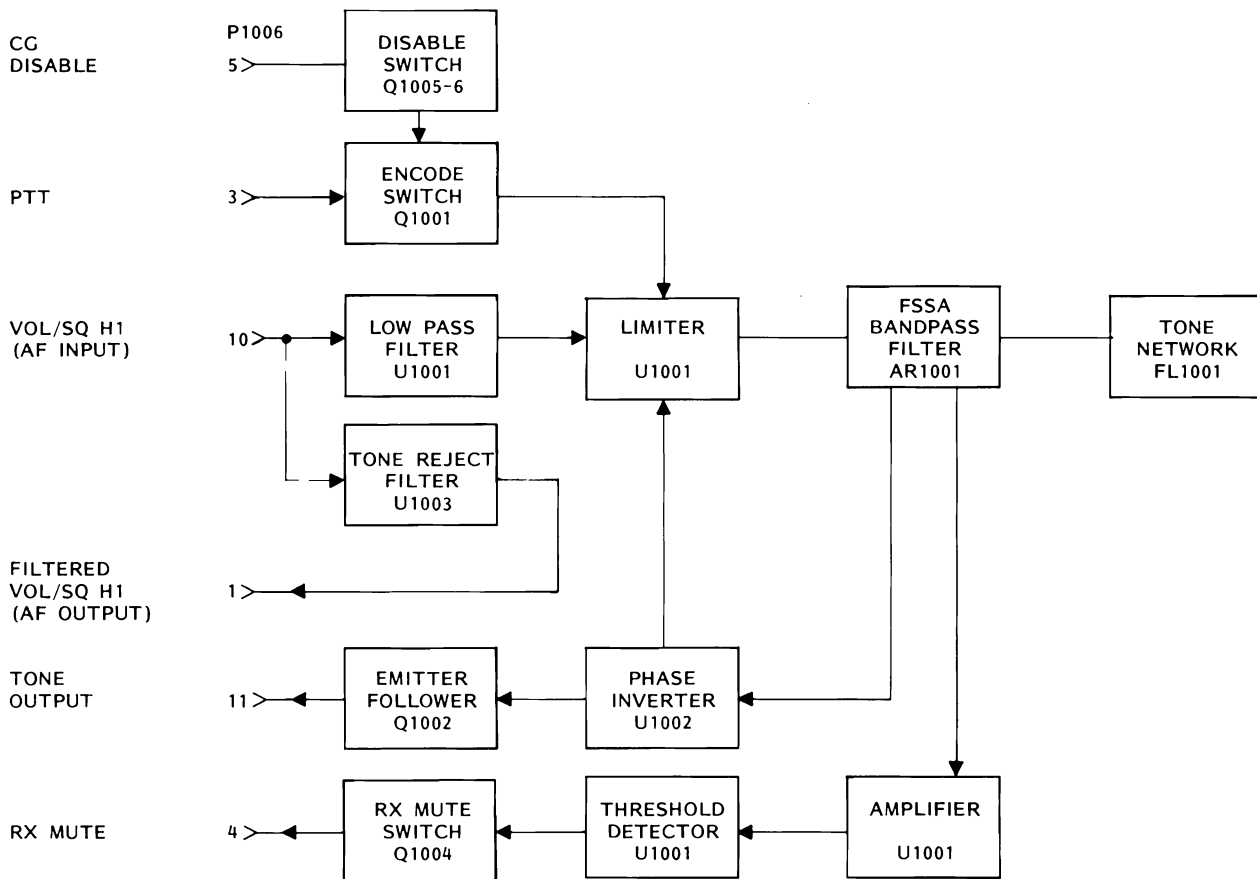

CHANNEL GUARD
FUNCTIONAL DIAGRAM
FIG. 1.

CHANNEL GUARD UNIT

For a functional diagram of the Channel Guard encoder/decoder refer to fig. 1.

Typical diagrams of the Versatone Network, Phase Inverting Amplifier, Encoder Limiter, Low Pass filter, Decode limiter, Amplifier and Threshold detector are provided in Figures 3 through 8. References to symbol numbers mentioned in the following text are found on the Schematic Diagram, Outline Diagram and Parts List.

OPERATION

A Channel Guard MONITOR switch located on the microphone hookswitch, controls the operation of the Channel Guard decode circuitry. When the switch is moved to the MON position, the Channel Guard decode function is disabled, allowing all calls to be heard. The encode function is controlled by the PTT switch and is enabled only when the PTT switch is operated. All transmitted calls are tone coded with the channel Guard frequency.

CIRCUIT ANALYSIS

FREQUENCY SWITCHABLE SELECTIVE AMPLIFIER

Frequency Switchable Selective Amplifier (FSSA) AR1001 is a highly stable active bandpass filter for the 71.9 Hz to 210.7 Hz frequency range. The selectivity of the filter is shifted across the bandpass frequency range by switching Versatone Networks in the filter circuit (See Figure 2.).

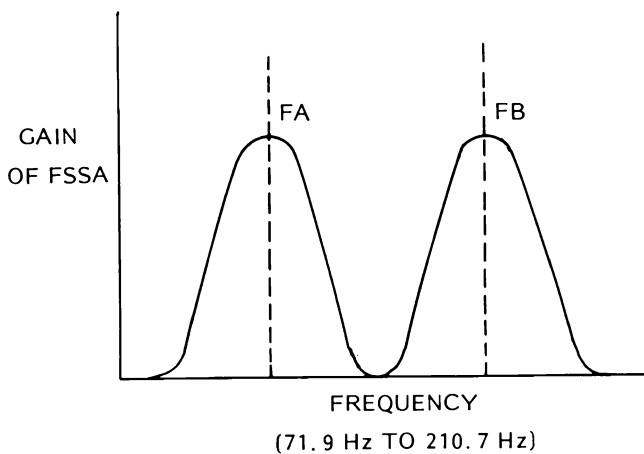

Figure 2 - Gain vs Frequency

In Figure 2, the gain of the FSSA is shown as a function of the tone frequency. The Tone Frequency is determined by the Tone

Network connected in the FSSA circuit. When Tone Network A is in the circuit, the maximum gain occurs at FA. When Tone Network B is in the circuit, the maximum gain occurs at FB.

TONE NETWORK

Versatone Network FL1001 is a precision resistor network with associated switching transistors. A typical Versatone Network is shown in Figure 3. Pins 3, 4 and 5 of the network are connected to ground.

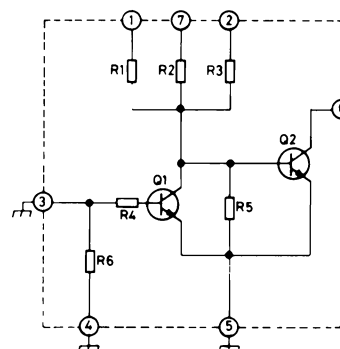

Figure 3 - Typical Versatone Network

CHANNEL GUARD UNIT

ENCODE

When PTT switch is operated the Channel Guard encode tone is generated by coupling the output of FSSA bandpass filter AR1001 back to its input through a phase inverting amplifier circuit and limiter circuit. The output of the FSSA is coupled from AR1001-1 to the input of the phase inverting amplifier at U1002-9. A typical phase inverting amplifier circuit is shown in Figure 4.

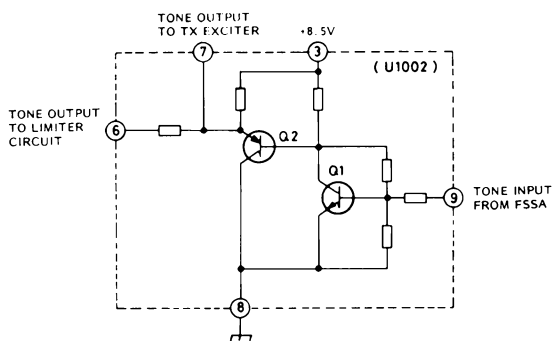

Figure 4 - Typical Phase Inverting Amplifier

Amplifier Q1 provides 180° phase shift of the tone frequency at the output of emitter follower Q2. The output of the phase inverting amplifier circuit is coupled from U1002-6 to the input of the limiter circuit at U1002-5. A typical limiter circuit is shown in Figure 5.

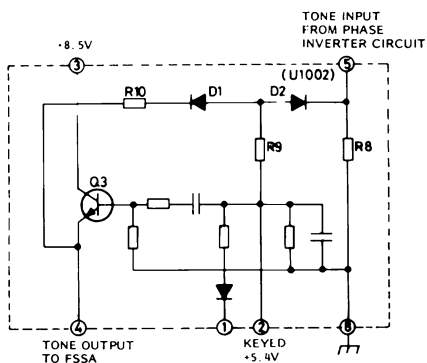

Figure 5 - Typical Encode Limiter Circuit

Limiting network D1, D2, R8, R9 and R10 sets the tone output coupled from U1002-4

to the input of the FSSA (AR1001-12) at 53 millivolts peak to peak.

The limiter circuit is also used as an encode switch. Keying the transmitter applies +5.4 Volts to U1002-2. This forward biases Limiter diodes D1 and D2 and momentarily turns Q3 on. Forward biasing D1 and D2 allows the circuit to oscillate.

Momentarily turning Q3 on starts the circuit oscillating. The tone frequency is determined by the tone network connected in the FSSA circuit.

The tone output of the encoder circuit is taken from U1002-7 and coupled through tone output amplifier Q1002 and modulation adjustment R1015 to the audio processor on the transmitter/receiver board.

DECODE

Audio, containing the correct frequency from P1006-10 (Volume Hi), is coupled to pin 1 of Decode Module U1001. Pin 1 of U1001 is the input of an active, three stage, low pass filter. The low pass filter attenuates frequencies over 210.7 Hz. A typical low pass filter is shown in Figure 6. The output of the low pass filter at U1001-15 is applied to U1001-14. U1001-14 is the input of a limiter circuit, limiting the output at U1001-13 to 55 millivolts peak to peak. A typical limiter circuit is shown in Figure 7. The output from the limiter is coupled to Pin 12 of FSSA AR1001. Since the tone is the proper frequency the FSSA will allow it to pass. The output of the FSSA is coupled from AR1001-1 to U1001-3. U1001-3 is the input to an amplifier circuit. The output of the amplifier at U1001-4 is coupled to the input of a threshold detector at U1001-6. A typical amplifier and threshold detector circuit is shown in Figure 8. When a tone is present, Q6 will conduct causing Q7 to conduct and +8.5 VDC to appear on the output of the threshold detector circuit (U1001-10).

CHANNEL GUARD UNIT

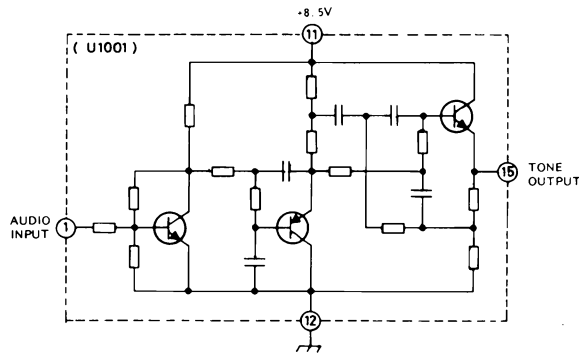

Figure 6 - Typical Low Pass Filter

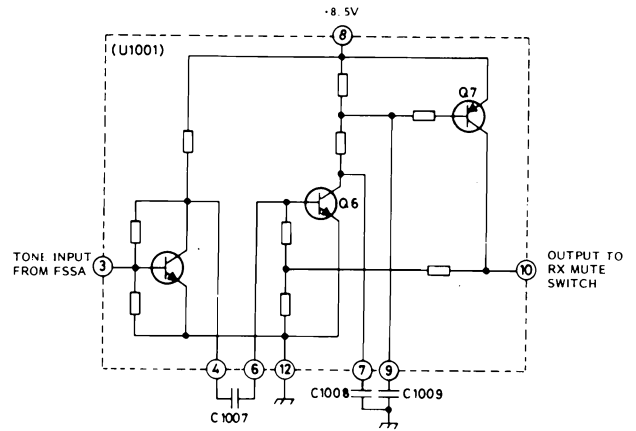

Figure 8 - Typical Amplifier and Threshold Detector Circuit

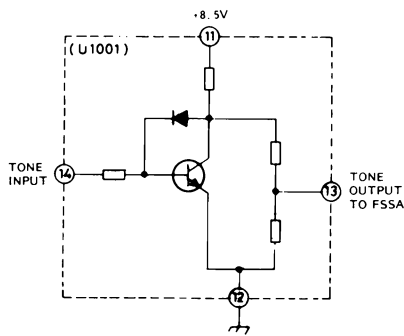

Figure 7 - Typical Decode Limiter Circuit

In the decode mode, when the tone decoder in U1001 detects the channel guard frequency, Q1003 turns Q1004 off. This unmutes the receiver audio. In the squelch mode, Q1004 is operating, grounding the RX MUTE lead and muting the receiver audio.

Audio from VOL/SQ HI is connected to the tone reject filter via P1006-10. The tone reject filter is an active filter consisting of U1003 and associated circuitry. All frequencies from 70 to 210.7 Hz are rejected by the filter, while passing all other audio frequencies via P1006-1 back to the receiver audio circuits.

ENCODE DISABLE

SERVICE HINT

The Encode Disable circuit has been incorporated as a maintenance aid for the serviceman. This circuit disables the Channel Guard encode circuit and allows the serviceman to make transmitter distortion and modulation checks without removing the cover from the radio.

The Encode Disable circuit is comprised of Q1005 and Q1006 and operates when a positive voltage (+8.5 - 14 VDC) is applied to P910-5 (Molex connector) on rear of radio. (Accomplished by temporarily jumpering P610-5 and P910-11). This positive voltage is applied to the base of Q1005 through the Interconnect/Multi-Frequency board, turning both Q1005 and Q1006 on. Q1006 applies +8.5 VDC to the base of PTT Switch Q1001, forcing it off. With Q1001 off, the operating voltage for the encoder IC U1002 and Encode Tone Output Stage transistor Q1002 is removed, preventing any tone output.

CHANNEL GUARD UNIT

CAUTION

When using the Encode Disable circuit do not remove microphone from mic hanger or put GC MON Switch in MON position. Damage to equipment will result.

INSTALLATION

The Channel Guard module is installed as shown on the installation diagram and jumpers are added or deleted as specified. The module is fastened to the chassis by 4 screws and plug P1006 is inserted in socket J906.

ADJUSTMENTS

ENCODER ADJUSTMENTS, TQ5003, TT5001

Turn the channel guard modulation potentiometer R1015 fully counterclockwise to remove the channel guard modulation.

Apply 1 V, 1000 Hz to the MIC-INPUT (J911-4/3) and adjust the Δf_{\max} potentiometer(s) for normal peak deviation minus the channel guard peak deviation.

Example:

Normal peak deviation= 5 kHz
Channel guard peak deviation= 750 Hz
Adjust deviation for 4250 Hz peak

Note

If the transmitter modulation distortion is checked at this stage, the test modulation must be reduced from the normal 70% of Δf_{\max} by a factor proportional to the actual maximum deviation for which the station was adjusted.

Remove the test modulation and adjust the channel guard potentiometer, R1015, to the required peak deviation.

Channel Guard deviation:

The channel guard deviation shall be requested by the customer, but if this infor-

mation is not available a preliminary setting of 15% of maximum normal deviation may be used.

DECODER CHECKING, TQ5003, TR5001

The function of the decoder is checked by applying an RF carrier to the antenna input.

Set the RF level to correspond with the normal squelch threshold.

Modulate the signal generator with the channel guard tone to approx. 500 Hz deviation.

Check that the audio channel is open only when the channel guard modulation is applied.

TONE REJECT FILTER CHECKING, FN5001

The function of the tone reject filter is checked by applying an RF carrier to the antenna input.

Set the signal generator level to 1000 μ V and modulate the signal with the channel guard tone to approx. 500 Hz.

Set the volume control to maximum and listen to the loudspeaker. The channel guard tone shall barely be audible.

CHANNEL GUARD UNIT

TECHNICAL SPECIFICATIONS

STANDARD TONE FREQUENCIES (Hz)				
71.9	88.5	107.2	131.8	162.2
74.4	91.5	110.9	136.5	167.9
77.0	94.8	114.8	141.3	173.8
79.7	97.4	118.8	146.2	179.9
82.5	100.0	123.0	151.4	186.2
85.4	103.5	127.3	156.7	192.8
				203.5
				210.7

Frequency Stability $\pm 0.5\%$ Supply Voltage

+8.5 V (RX or TX)

Current Drain

25 mA

Temperature Range -30°C to $+60^{\circ}\text{C}$

SEQUENTIAL TONE UNITS

TQ5004 AND TQ5005

GENERAL

The sequential tone units TQ5004 and TQ5005 are combined tone transmitter-tone receiver units with the transmitter and receiver functions being independent of each other. They can process 3, 4, or 5-tone signals, one sequence for tone reception and two sequences for transmission.

The units are built on two printed circuit boards, a TONE BOARD and a LOGIC BOARD, which mount together to a sandwich unit with the soldering sides facing each other. The unit fits mechanically into the CQM5000 radiotelephone on the interconnect board side, and the electrical design appears from the block diagram, see fig. 1. and fig. 2.

For TQ5004 the tone frequencies are the ZVEI (Storno) series, 885 Hz to 2800 Hz, and for TQ5005 the tone frequencies are the CCIR series, 960 Hz to 2110 Hz.

The combinations for the tone receiver and transmitter sequences are selected by coding a PROM (Programmable Read Only Memory). Before placing it on the logic board, see coding and strapping. For the tone transmitter sequences up to 4 tones may be coded to be selected from a keyboard on the control panel CP5003.

The following description applies to both TQ5004 and TQ5005 unless otherwise noted.

STANDBY CONDITIONS

When the radio equipment is turned on it will be in standby condition, and the tone unit, TQ5004/TQ5005, is in the tone receive mode and set to the 1st tone of the receive code.

TONE RECEPTION

Reception of a sequential tone signal that matches the combination of the code will cause the following events to take place:

The KEY BLOCKING is cancelled (Q127 ON).
The LOUDSPEAKER BLOCKING is cancelled (Q130 OFF).

The visual LED CALL INDICATOR will start flashing.

If the unit is connected for AUTO RECEIPT/ACKNOWLEDGE a correctly received tone call will automatically key the sequential tone transmitter and transmit its own ID, and after having generated the last tone of a sequential tone signal, the unit reverts to the condition described above, i.e. the loudspeaker is on.

TONE TRANSMISSION

When the loudspeaker is turned on, either by a tone call or by pressing the LS IN button, the tone transmitter can be keyed and will generate the sequential tone signal.

With a tone length of 70 ms (milliseconds) for the ZVEI and 100 ms for the CCIR tone series the interval from pressing the TONE KEY button to the start of the 1st tone is approximately 220 ms for the TQ5004 (ZVEI) and 320 ms for the TQ5005 (CCIR). When using 3 or 4 tones in the transmitter sequence this interval may be extended if the PROM is programmed to give INHIBIT to the 4-to-16 Bit Decoder.

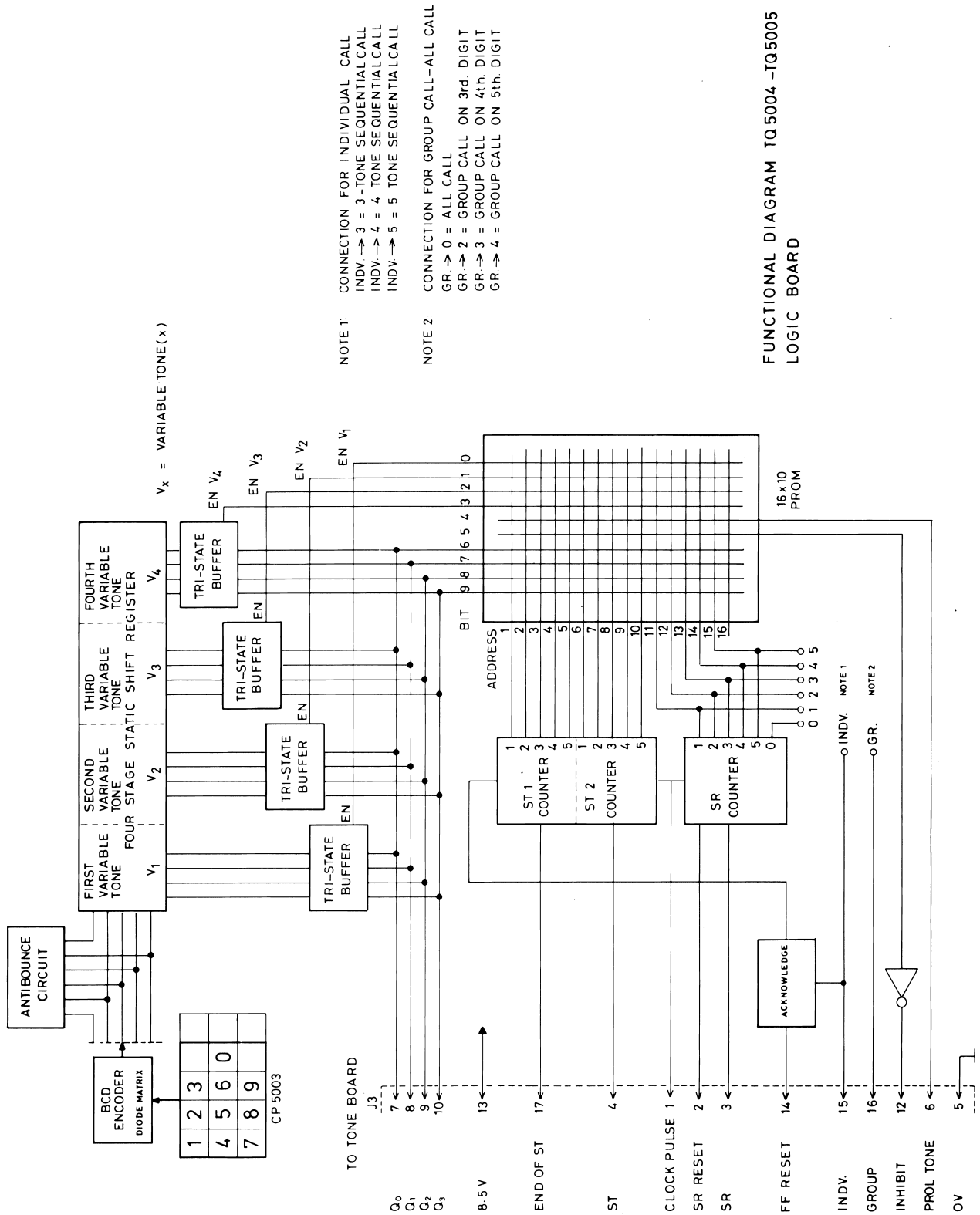

FIG. 1. LOGIC BOARD FUNCTIONS

SEQUENTIAL TONE UNITS

TQ5004 AND TQ5005

GENERAL

The sequential tone units TQ5004 and TQ5005 are combined tone transmitter-tone receiver units with the transmitter and receiver functions being independent of each other. They can process 3, 4, or 5-tone signals, one sequence for tone reception and two sequences for transmission.

The units are built on two printed circuit boards, a TONE BOARD and a LOGIC BOARD, which mount together to a sandwich unit with the soldering sides facing each other. The unit fits mechanically into the CQM5000 radiotelephone on the interconnect board side, and the electrical design appears from the block diagram, see fig. 1. and fig. 2.

For TQ5004 the tone frequencies are the ZVEI (Storno) series, 885 Hz to 2800 Hz, and for TQ5005 the tone frequencies are the CCIR series, 960 Hz to 2110 Hz.

The combinations for the tone receiver and transmitter sequences are selected by coding a PROM (Programmable Read Only Memory). Before placing it on the logic board, see coding and strapping. For the tone transmitter sequences up to 4 tones may be coded to be selected from a keyboard on the control panel CP5003.

The following description applies to both TQ5004 and TQ5005 unless otherwise noted.

STANDBY CONDITIONS

When the radio equipment is turned on it will be in standby condition, and the tone unit, TQ5004/TQ5005, is in the tone receive mode and set to the 1st tone of the receive code.

TONE RECEPTION

Reception of a sequential tone signal that matches the combination of the code will cause the following events to take place:

The KEY BLOCKING is cancelled (Q127 ON).
The LOUDSPEAKER BLOCKING is cancelled (Q130 OFF).

The visual LED CALL INDICATOR will start flashing.

If the unit is connected for AUTO RECEIPT/ACKNOWLEDGE a correctly received tone call will automatically key the sequential tone transmitter and transmit its own ID, and after having generated the last tone of a sequential tone signal, the unit reverts to the condition described above, i.e. the loudspeaker is on.

TONE TRANSMISSION

When the loudspeaker is turned on, either by a tone call or by pressing the LS IN button, the tone transmitter can be keyed and will generate the sequential tone signal.

With a tone length of 70 ms (milliseconds) for the ZVEI and 100 ms for the CCIR tone series the interval from pressing the TONE KEY button to the start of the 1st tone is approximately 220 ms for the TQ5004 (ZVEI) and 320 ms for the TQ5005 (CCIR). When using 3 or 4 tones in the transmitter sequence this interval may be extended if the PROM is programmed to give INHIBIT to the 4-to-16 Bit Decoder.

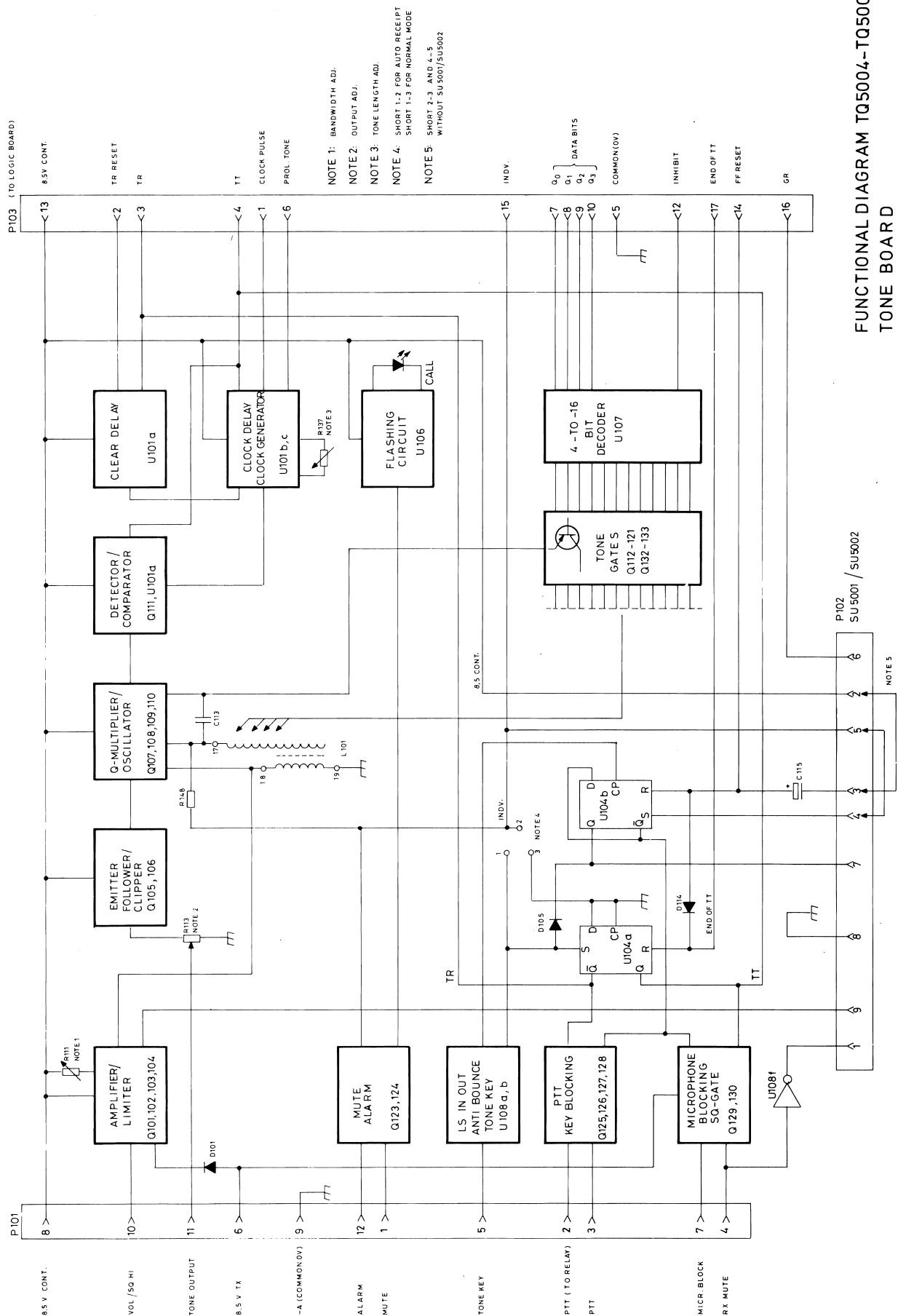

FUNCTIONAL DIAGRAM TQ5004-TQ5005 TONE BOARD

FIG. 2. TONE BOARD FUNCTIONS

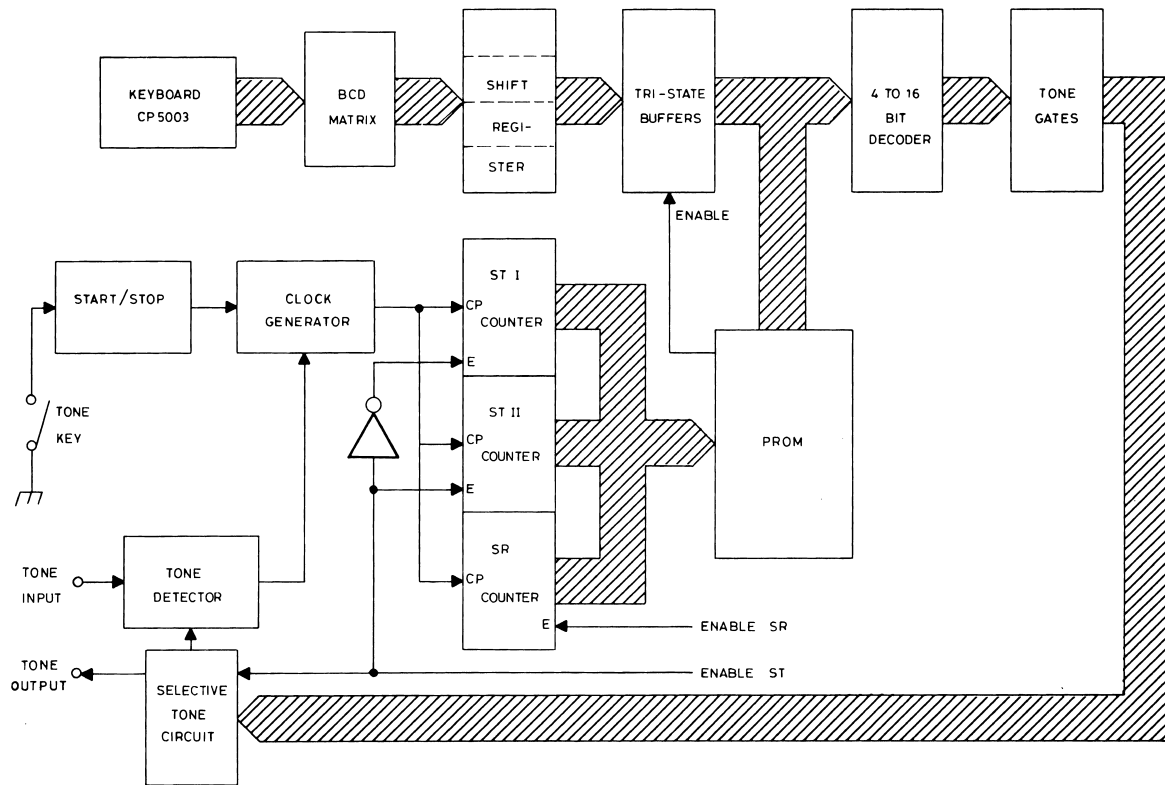

FIG. 3. DATA FLOW CHART

The RF transmitter remains keyed for approximately 600 ms with coding and strapping for one-sequence transmission, and 1100 ms for two-sequence transmission in TQ5004, and 850 ms for one-sequence transmission, and 1550 ms for two-sequence transmission in TQ5005, even if the TONE KEY is depressed for a shorter or longer period.

During the keying of the transmitter the microphone amplifier will be blocked and the blocking signal will disappear after the last tone, i. e. when the unit reverts to standby.

Before transmitting commences it is possible to select up to 4 tones by entering them on the keyboard. The tones are then inserted in the transmitted code in accordance with the coding of the PROM.

The selected tones may be 0-9, and on each side (in the code) a repeat tone must be inserted, refer to Coding and Strapping.

The strapping is performed on the p. c. b. and it is possible to select the "X" tone in place of the "A" tone (Alarm) and the "Y" tone in place of the "R" tone (Repeat). It is impossible to select the A, R, X, and Y tones from the keyboard.

MODE OF OPERATION

Logic levels are as follows:

"1" = ~8.5 V

"0" = ~0 V

TONE RECEPTION

In standby the 1st tone receiver code in the PROM is applied to the 4-to-16 BIT DECODER which selects the proper tone gate.

The unit is set to the sequential tone reception mode awaiting a call, and when a tone

PULSE-TIME DIAGRAM FOR 5-TONE, SEQUENTIAL TONE RECEPTION IN TQ5004 AND TQ5005

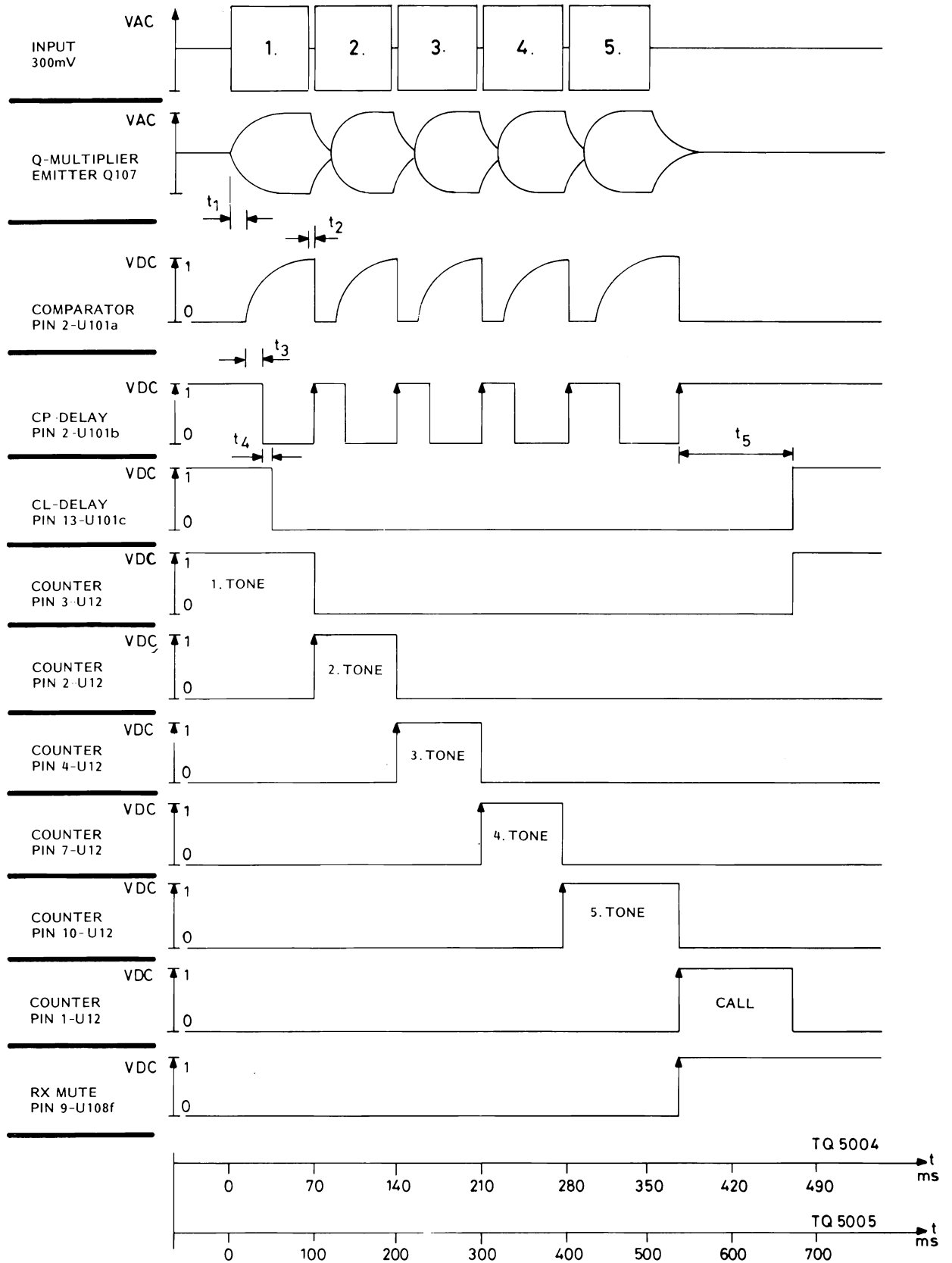

t_1 = SELECTIVE CIRCUIT BUILD-UP TIME
 t_2 = DECAY TIME
 t_3 = CLOCK-DELAY

t_4 = DELAY CHARGING TIME
 t_5 = CLEAR DELAY

FIG. 4. 5-TONE SEQUENTIAL RECEPTION

PULSE-TIME DIAGRAM FOR 5 TONE SEQUENTIAL CALL TQ5004

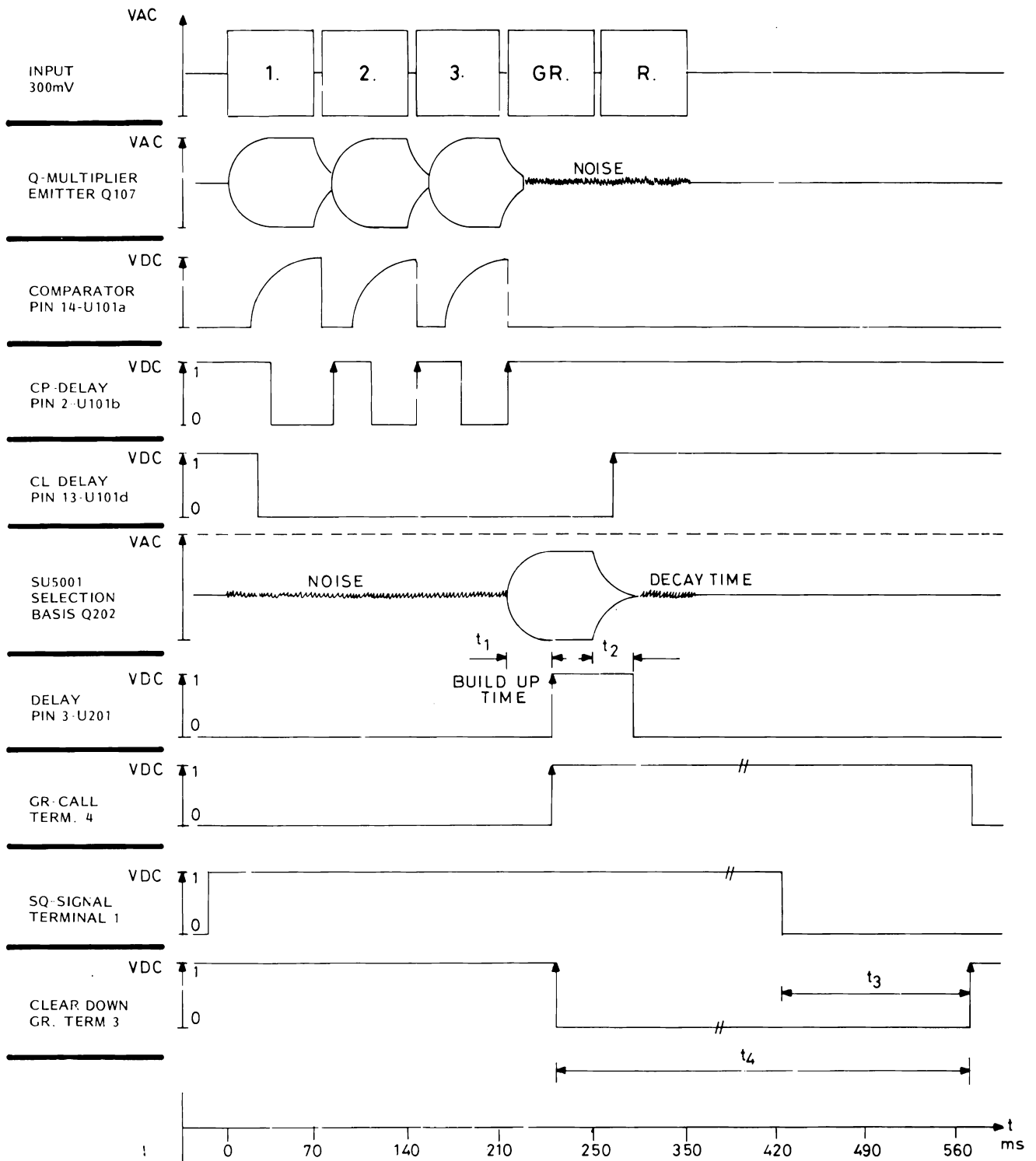

t_1 BUILD-UP TIME + DELAY
 t_2 DELAY TIME + HANGTIME
 t_3 SQ-DELAY
 IN PERIOD t_4 THE AUTOMATIC RECEIPT, TONE KEY,
 AND LS IN/OUT ARE INHIBITED.

FIG. 5. 5-TONE CALL WITH GROUP CALL

signal having the proper code is applied to the input it is processed as follows:

The 1st tone is amplified and limited in the input stage. The tone is then, via the coupling link, applied to the selective circuit.

The active part of the selective circuit is a Q-multiplier which also operates as an oscillator when the circuit is working as part of the tone transmitter.

If the level of the 1st tone is within the sensitivity range of the tone receiver the detected signal will switch the output of the comparator U101a. Approximately 17 ms later, caused by the CLOCK DELAY circuit, the Schmitt trigger output, U101b goes logic "0". At the same time the Schmitt trigger circuit rapidly sets up the CLEAR DELAY circuit, U101d, in order to remove the reset on the tone receiver counter, U12.

When the first tone ceases the Schmitt trigger reverts to standby condition, output logic "1", and the positive leading edge is fed to the clock input of the counters. As only the tone receiver counter is enabled this steps forward and the code corresponding to the 2nd tone is applied to the 4-to-16 BIT DECODER. The proper tone gate for the 2nd tone is now open.

The transistor collectors of the tone gates are all tied to one of the tone coil terminals. The tone receiver is now set up to receive the 2nd tone of the signal and remain in this state for approximately 120 ms, provided that the 2nd tone is not accepted. The time elapsing is determined by the CLEAR DELAY circuit.

Except for the requirement of a tone length of approximately 40 ms the tone receiver is independent of the duration of the tone bursts, because the counter switches to the next PROM input at the end of the preceding tone. If the 2nd tone is not accepted within approximately 120 ms the counter is reset to standby, i. e. ready for the 1st tone.

The 2nd, 3rd, 4th, and 5th tone of the sequential signal is received as described for the 1st tone.

When the last tone has been accepted, the counter information is read out to latch U104b, which is set and cancels the key and loudspeaker blockings. At the same time the CALL indicator is turned on and LED D107 starts to blink.

The ALARM relay driver Q123 goes on during the last tone period and turns off approximately 70 ms later.

An accepted call may also release an automatic receipt transmission, ACKNOWLEDGE, if this option is used.

TONE TRANSMISSION

All tones used in the tone transmitter codes are programmed in the PROM.

With the loudspeaker turned on, either by a call or by manually pressing the LS in/out button, pressing the TONE KEY button initiates the following series of events:

The positive pulse from the TONE KEY button sets latch U104a whose Q and \bar{Q} outputs control the internal switching from receive mode to transmit mode. U104a also controls the Transmitter Key Switch, Q126-Q125, and the Microphone Blocking transistor Q129.

When the Clock Generator U101c starts to run, the comparator U101a and the counter U12 are both inhibited by the Q-output of U104a. The \bar{Q} -output keys the RF transmitter, inhibits the Clock Delay circuit, and turns Q108 on which increases the gain of Q-multiplier Q107 to make it oscillate when the tone gates are opened.

The clock generator pulses from U101c are applied to the counters, U10 and U11, the repetition rate being 70 ms for TQ5004 and

PULSE-TIME DIAGRAM FOR 5 TONE SEQUENTIAL CALL
TRANSMITTING IN TQ5004 AND TQ5005

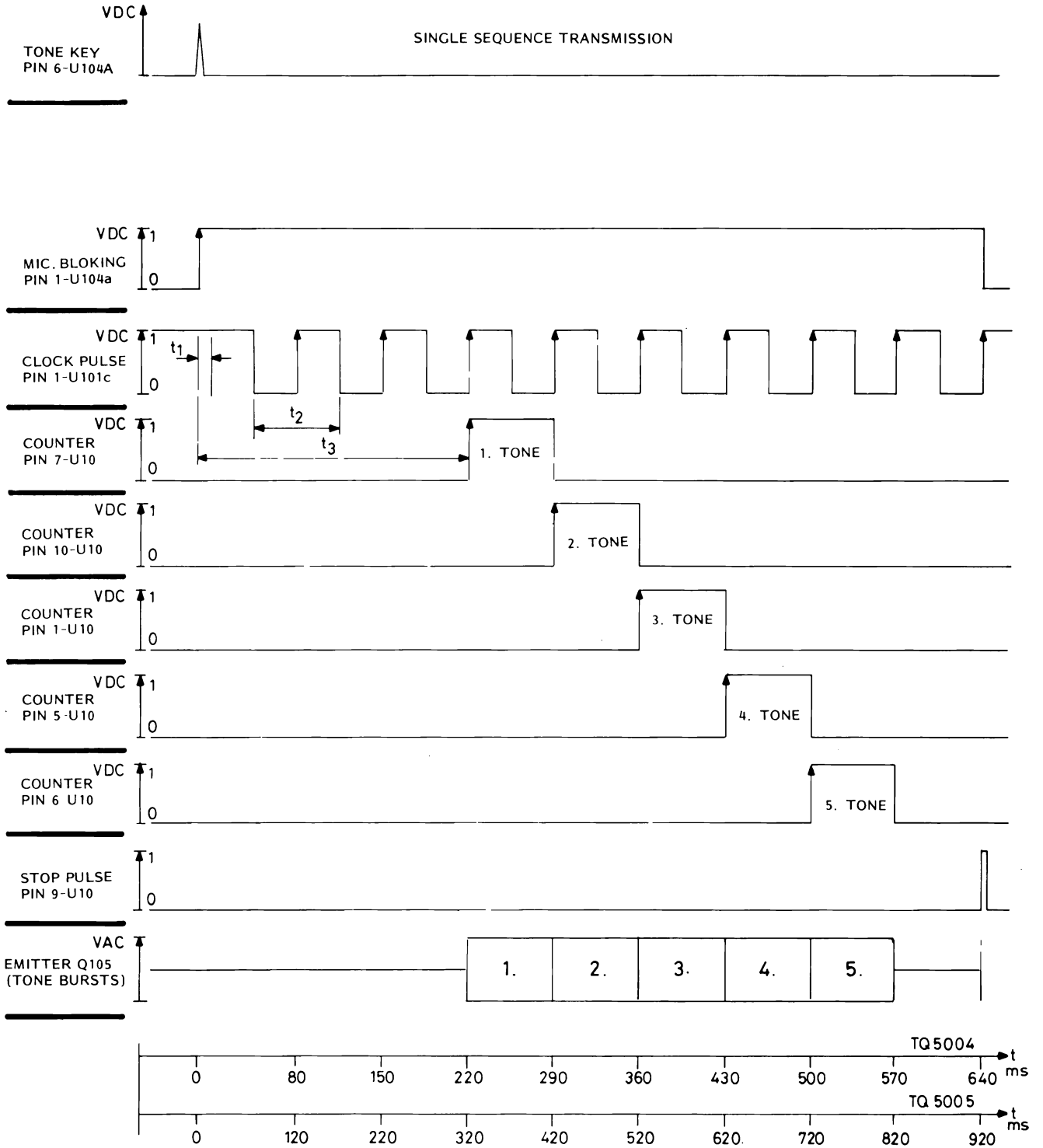

LOUDSPEAKER MANUALLY TURNED ON
 t_1 CHARGING TIME FOR CLOCK GENERATOR
 t_2 CLOCK PULSE PERIOD (TONE LENGTH)
 t_3 UNMODULATED PULSES BEFORE THE 1 ST TONE

FIG. 6. 5-TONE SEQUENTIAL TRANSMISSION

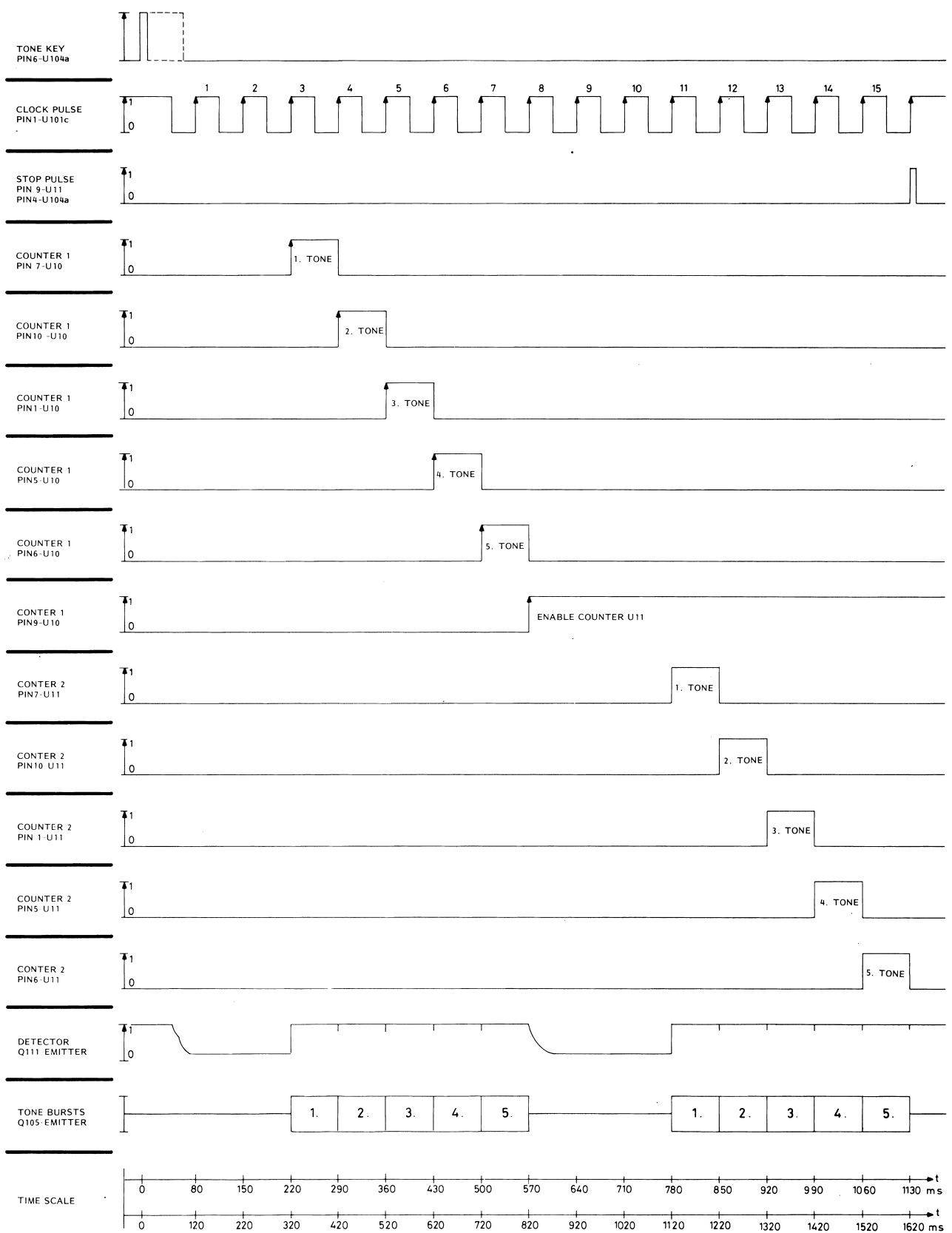

FIG. 7. DUAL SEQUENCE TRANSMISSION

100 ms for TQ5005. This repetition rate is set by R137.

When the 3rd clock pulse reach counter U10 the 1st tone transmitter code of the PROM is selected and through the 4-to-16 BIT DECODER the 1st tone transmitter gate is opened and the tone oscillator, Q107, generates the 1st tone of the transmitter code. The oscillator output passes an emitter follower, Q105, before reaching the output terminal. The output is set with potentiometer R113.

The 4th, 5th, 6th, and the 7th clock pulse consecutively selects the proper codes in the PROM for the 4-to-16 BIT DECODER and accomplish the sequential tone signal.

If only one sequence is required the 8th clock pulse will reset the latch U104a and the unit

reverts to the tone receive mode with the loudspeaker still being on.

However, if a 2nd sequence is required the next counter U11 is enabled. The following two clock pulses will not produce an input to the PROM and therefore no tones are generated. The following 5 clock pulses will, through the PROM and the 4-to-16 BIT DECODER produce a proper 2nd tone sequence, and thereafter the unit reverts to standby with the loudspeaker on.

As an option the PROM may be coded to accept up to 4 tones being variable and selectable from the Key Board. The position of these tones in the tone transmitter sequences are coded into the PROM.

TONE BOARD CIRCUIT DESCRIPTION

INPUT AMPLIFIER AND LIMITER

The transistors Q101, Q102, and Q103 form a differential input amplifier/limiter followed by the resonant circuit driver Q104.

The received tone signals are amplified, the amplifier gain being constant and determined by the ratio of R106 to R107, and signal levels higher than the minimum sensitivity (approx. 85 mV) will cause limiting to occur. The tone signal is then applied to the Group Call unit SU5001 or All Call unit SU5002, if used (terminal 9), and to the resonant circuit driver Q104 which operates as a current generator with its collector connected to a separate winding on the tone coil.

The sensitivity and thus also the tone receiver bandwidth is adjustable and set with potentiometer R111.

The input amplifier is blocked when the TONE KEY button is depressed (and the TRANSMIT key) which applies 8.5 V TX to the base of Q101 through D101.

Less than 100 ms after the unit reverts from the tone transmit mode it is ready to receive a call.

RESONANT CIRCUIT

The bandpass filter consists of tone coil L101 and capacitor C113. The signal from the input amplifier is coupled to the parallel resonant circuit via the coupling link. The circuit is tuned to the tone frequencies by the tone gates which switch the coil taps into the circuit in parallel with capacitor C113.

Q-MULTIPLIER, LIMITER, REFERENCE VOLTAGE, AND TONE DETECTOR

The Q-multiplier consists of Q107, the limiter of Q109; the reference voltage is derived from Q110, and Q111 is the tone detector.

A portion of the selected tone signal is fed, via the Q-multiplier Q107, back to the coupling link and in phase with the input signal. This increases the bandpass filter Q-factor to approx. 30. The resistors R123-R148 linearize this factor throughout the band, and the NTC resistor, R120, in the Q107 emitter compensates the Q-factor variations with ambient temperature.

The tone signal is rectified by transistor Q111 and the resultant d. c. voltage is applied to comparator U101a. Q108 is turned on by U104a when depressing the TONE KEY, and this increases the feedback so much that the resonant circuit and Q107, which is the active component, form an oscillator. The signal voltage across the resonant circuit is amplitude limited by Q109 in order to obtain a constant signal output level from the oscillator and to reduce the decay time for strong signals.

The gate transistor bias and the detector bias voltages are derived from Q110.

TONE OUTPUT EMITTER FOLLOWER AND CLIPPER

The output stage consists of the emitter follower Q105 and its frequency characteristic is flat because the tone signal is connected directly to the splatter filter. Potentiometer R113 is the generator impedance for the operational amplifier in the splatter filter.

Because of the d. c. shifts in the oscillator circuit a peak will appear of the start and end of the tone signals. These peaks will be limited by Q106.

COMPARATOR

The comparator is built around U101a and its trigger level is determined by the voltage divider R130-R131//R181 and controlled by the Q-output of Latch U104a.

The rectified tone signal increases the d. c. voltage to the non-inverting input of the comparator, and when the level exceeds the reference voltage the output of U101a will change from being a short to ground (logic "0") to the off state (logic "1"). The time of this state is determined by the length of the tone and when the tone ceases the output reverts to a short to ground, i. e. standby condition. When depressing the TONE KEY button U101a is inhibited in its standby state by the Q-output of U104a.

CLOCK DELAY CLOCK GENERATOR

The Clock Delay time is determined by R132 and C107, and Schmitt Trigger U101b. In standby the charge of capacitor C107 is neutral due to the discharge through the output of U101a. The Clock Generator U101c is inhibited in its off position.

The reference voltage, which is common to U101b and U101c, is via voltage divider R133, R134, R135 applied to the non-inverting inputs. When the comparator U101a is activated by the tone, the voltage across C107 will begin to go positive.

After 17 ms (Clock Delay) the Schmitt Trigger U101b will be activated and its output voltage will drop to zero (logic "0"). After the end of the tone C107 again discharges via U101a's output and Schmitt Trigger U101b changes its state.

This produces a positive going voltage edge at the U101b output which is applied to the clock inputs (CP) of the counters U10, U11, and U12 whose outputs switch the circuitry to the next tone gate.

If the Comparator detects a new tone before the Clear Delay reverts to standby the procedure is repeated.

The Comparator will, in its inhibited state (TONE KEY activated), keep U101b off. Simultaneously the Clock Generator U101c is released by biasing D104 off. This enables C108 to charge through the resistors R136, R137, and R138 until reaching the common reference voltage, and the output of U101c drops to 0 V. This voltage transistion is, via R134, feed back to the non-inverting input of U101b and thus causes a hysteresis. C108 now discharges to the lower voltage level and this cycle keeps repeating itself.

The positive pulses so appearing of the outputs of U101b and U101c are used as clock input to the counters U10 and U11. The period time is adjusted by means of resistor R137 to 70 ms for TQ5004 or 100 ms for TQ5005.

A tone can be prolonged by applying a logic "0" through D109 to the base of Q131, which then turns off and R202 is switched into the circuit.

CLEAR DELAY

Comparator U101d is controlled by the Schmitt Trigger U101b. In standby the charge of C109 is neutral because D103 is reverse biased. The output level of U101d corresponds to the supply voltage 8.5 V, i.e. logic "1" and counter U12 is cleared and set to the 1st tone gate.

Triggering U101b enables C109 to be charged via D103 and R140, and when the voltage at C109's negative pole has fallen to the reference level, U101d changes its output to 0 V (logic "0") and releases the counter U12, which now is ready to receive the clock pulses.

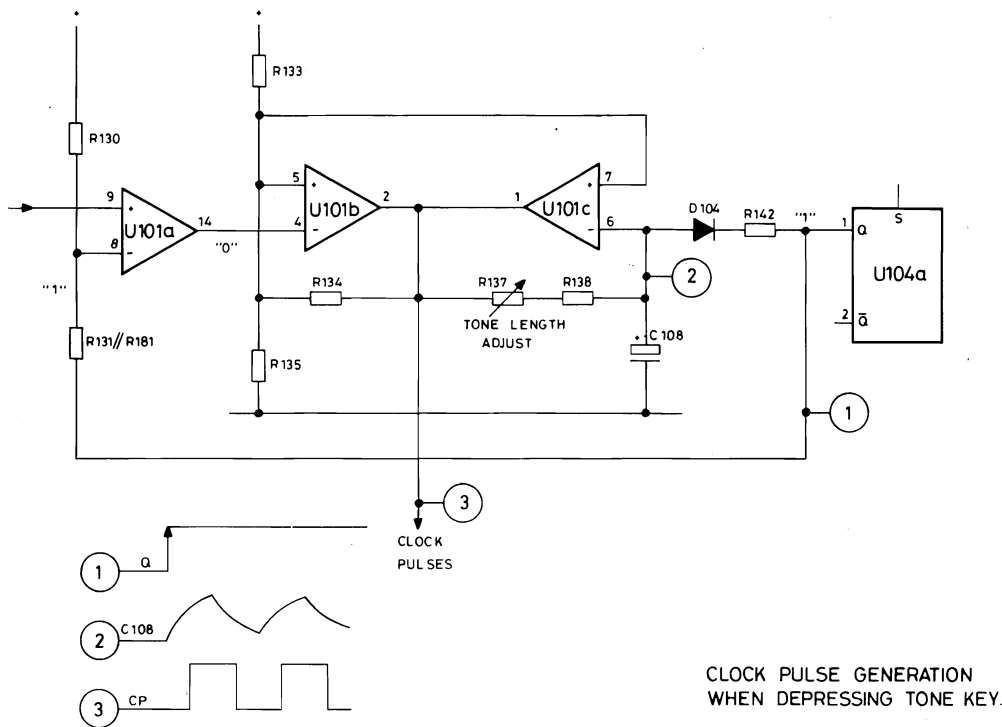

FIG. 8. CLOCK PULSE CIRCUITRY

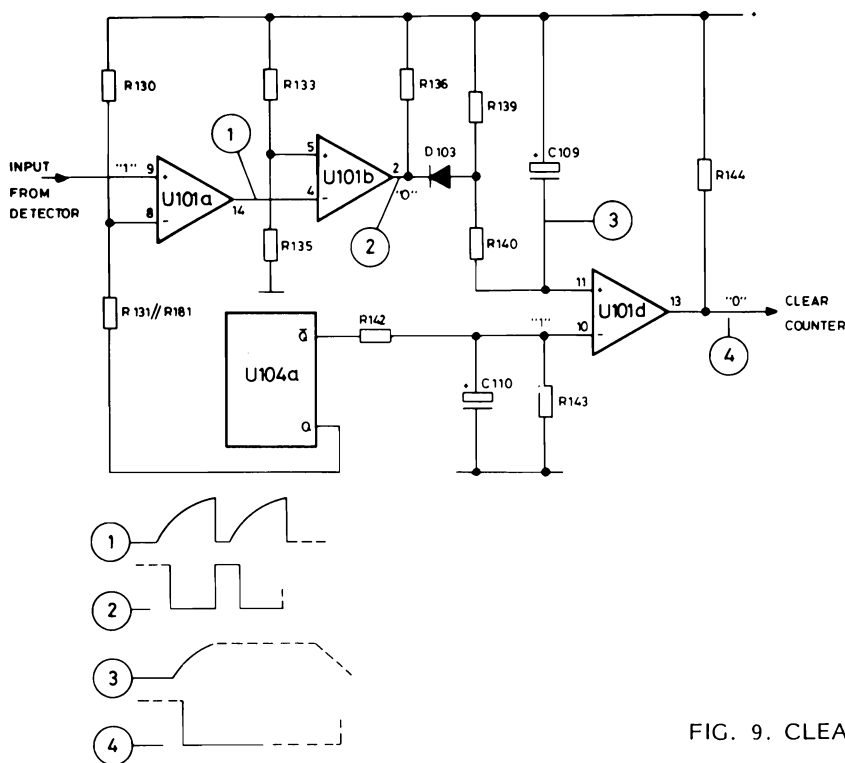

FIG. 9. CLEAR DELAY CIRCUITRY

The U101d reference level is controlled by U104a's \bar{Q} -output which in standby is approximately 8.5 V, i.e. logic "1".

Depressing the TONE KEY button causes the reference voltage to fall to 0 V and U101d is blocked in its standby position, and hence Counter U12 is disabled accordingly. As long as the Schmitt Trigger U101b is active, D103 will maintain the charge of C109 and, when the last tone ceases, U101b reverts to standby and D103 is reverse biased. The discharge time of C109 is determined by R139 and R140 which within approx. 120 ms reduces the capacitor voltage until it corresponds to the reference level.

The U101d output voltage now returns to 8.5 V and clears the Counter U12, after which the 1st tone gate is reengaged and the tone receiver is ready to receiver a new call. As the intervals between the individual tones in a sequential tone call are far less than the above mentioned 120 ms, the Clear Delay will retain its state during the call plus the 120 ms.

4-TO-16-BIT DECODER AND TONE GATES

In order to select the correct tones the taps on the tone coil are each connected to the collector of a tone gate transistor (Q112-Q121, Q132 and Q133).

When a tone gate input is logic "1", the corresponding tap on the coil is connected in parallel to capacitor C113 in order to establish the resonant circuit of the Q-multiplier/Tone generator.

The 4-to-16-Bit Decoder will, if the Inhibit input is logic "0", open a tone gate corresponding to the data inputs ($Q_0-Q_1-Q_2-Q_3$) from the Logic Board.

ANTIBOUNCE, LOUDSPEAKER IN/OUT, TONE KEY, AND CALL INDICATOR FLASHING CIRCUIT

As latch for the tone receiver and tone transmitter functions a dual D-Flip-Flop, U104, is

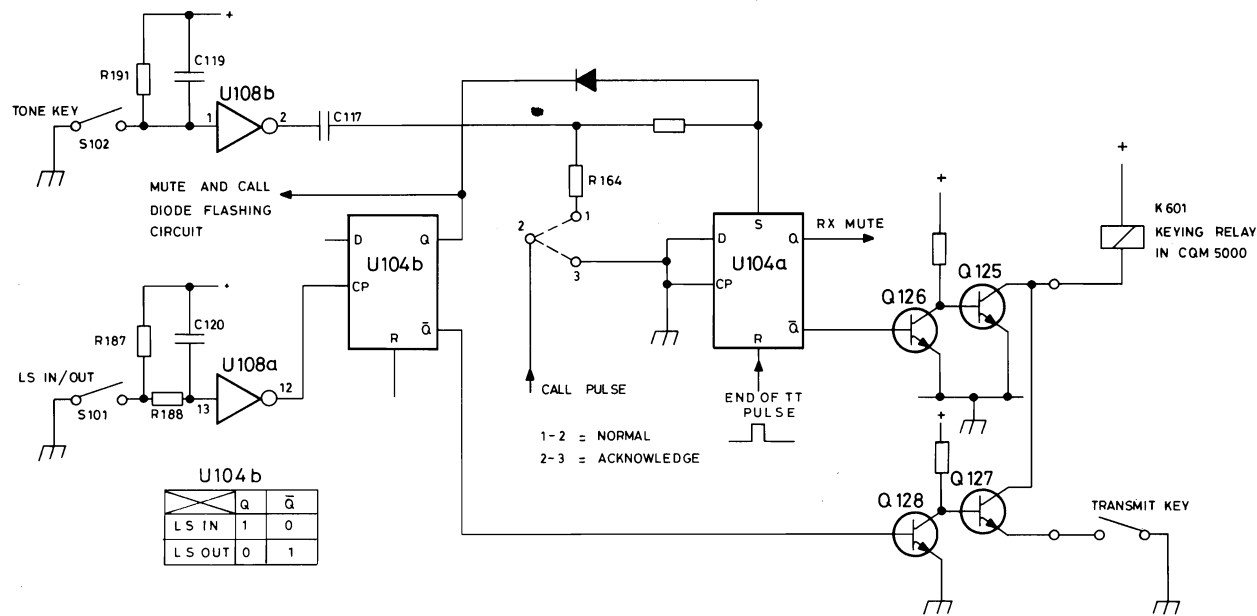

FIG. 10. LS IN/OUT AND TONE CIRCUITRY

employed, of which U104a's set input is controlled by U104b via diode D105. A Schmitt Trigger, U108a prevents that contact-bounce in the LS IN/OUT switch operates the latch.

After a received tone call, or after having manually opened the loudspeaker, the Flashing Circuit U106, with its associated components, will start flashing the CALL LED (D107).

When applying the supply voltage, 8.5 V, U104b is forced into position 'LS OUT' by the positive pulse fed to the latch reset input via C115. The call pulse is derived from one of Counter U12's outputs on the Logic Board, and applied to U104b's set input, and, according to NOTE 4 on the diagram, to U104a as a receipt pulse (Acknowledge).

After a received tone call, U104b will be in position "LS in" until manually reset by pressing the "LS IN/OUT" button. The information from the Tone key input terminal to the 'set' terminal of U104a is shortcircuited by the Q-output of U104b via diode D105 when the loudspeaker is off. To perform a tone

call, U104b must be set manually by pushing the LS IN/OUT button in order to reverse bias D105.

MUTE AND ALARM FUNCTIONS

The Mute function takes the information from the Q-output of U104b, and Q124 is on after a call or manual opening of the loudspeaker. The Alarm transistor Q123 is on for a short time after the 5th tone (70 ms) for triggering the Alarm Relay unit SU5003.

PUSH-TO-TALK TO RELAY AND PUSH TO TALK FUNCTIONS

When the TONE KEY button is depressed Q125 will go on and operate the relay. Q125 is controlled by the information on the \bar{Q} -output of U104a.

The normal keying of the RF transmitter is achieved by shorting terminal 3 to ground. If the tone receiver is not open, Q127 is off and prevents keying of the transmitter.

MICROPHONE BLOCKING AND RX MUTE

When the transmitter is keyed in normal transmit mode, the microphone amplifier is supplied via Q129. When the TONE KEY button is pressed, U104a turns Q129 off and the microphone amplifier is blocked.

After reception of a correct tone call, or manual opening of the loudspeaker (LS IN/OUT), Q130 switches off and cancels the clamping of the RX Mute lead, so that only the noise squelch decides whether the audio channel is open or not.

LOGIC BOARD CIRCUIT DESCRIPTION

KEY BOARD, DECIMAL TO BCD ENCODING AND ANTIBOUNCE

From the Key Board pulses enter the circuit and are encoded to BCD format in a diode matrix. All pulses from the Key Board passes the antibounce circuit (Q1 and U6d) which forms the clock pulses for the Shift Registers.

pulses from the antibounce circuit. When 4 clock pulses have entered the Shift Registers, i. e. 4 digits have been keyed into the circuit, the registers are full. Digits further keyed in will shift out the digits keyed in 4 positions earlier so the Shift Registers will only contain the last 4 key board entries. The Shift Registers work in the serial input - parallel output mode.

SHIFT REGISTERS AND DATA BUFFERS

The data from the BCD encoder are shifted into the Shift Registers, U1 and U2 by clock

The parallel outputs of the Shift Registers connect to the input of Tri-state Buffers whose output states are controlled by the PROM via U6a, U6b, U6c, and U6e. According

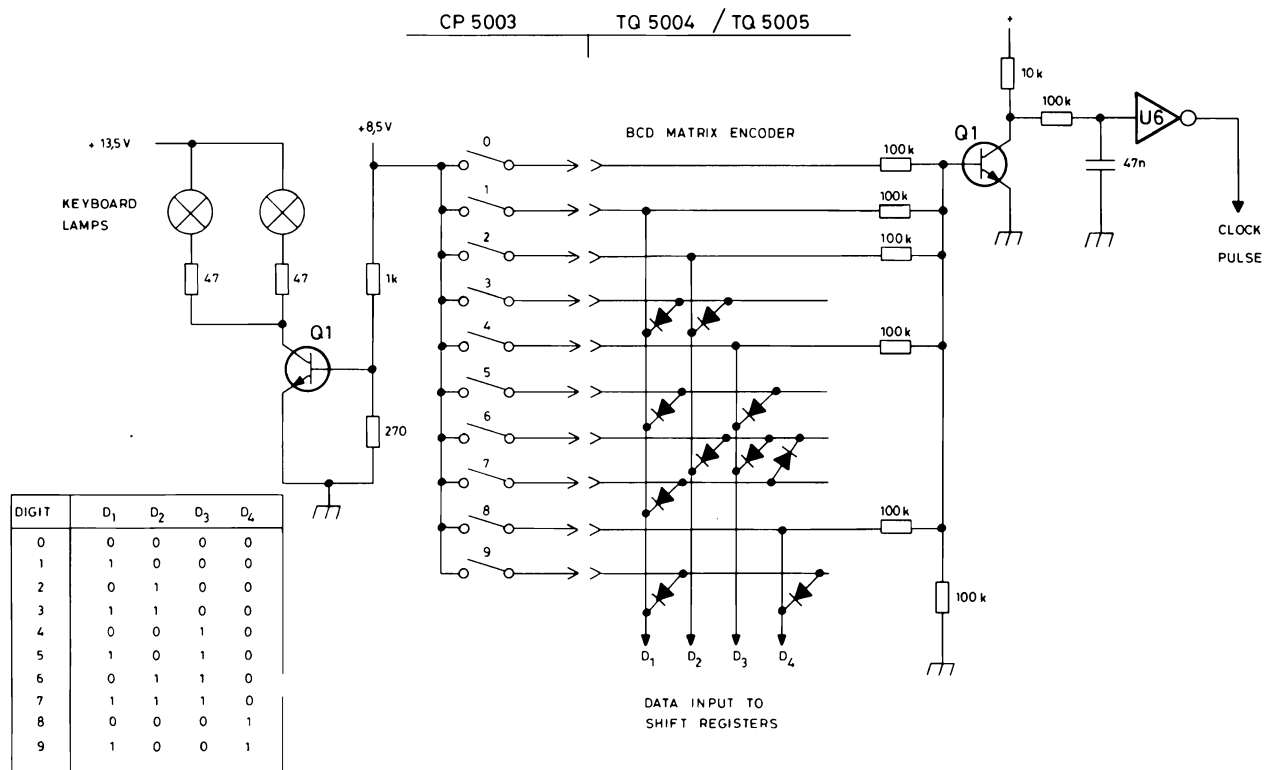

FIG. 11. BCD ENCODER - CLOCK PULSE CIRCUITRY

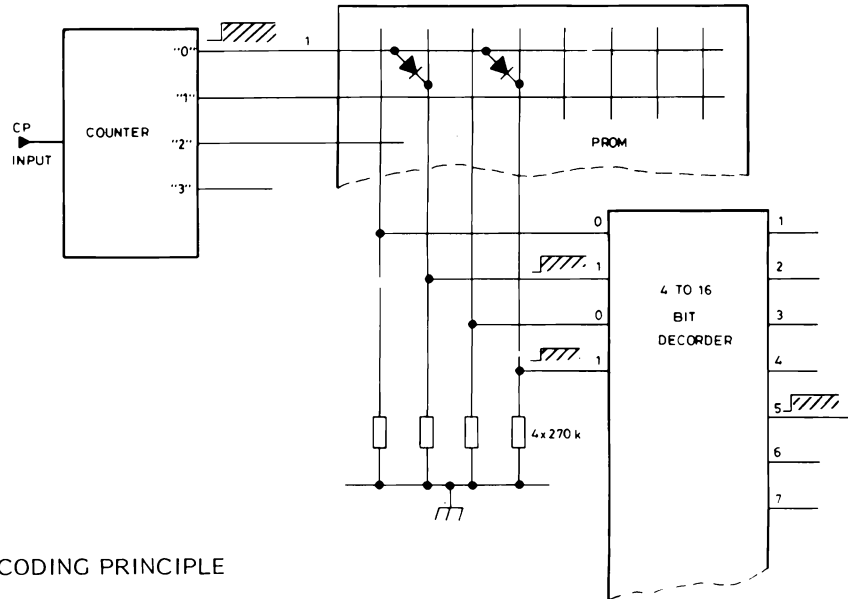

FIG. 12. PROM DECODING PRINCIPLE

to the codes programmed into the PROM the Tri-state Buffers, U3, U4, and U5 will place the data for the variable tones on the data bus to the 4-to-16 Bit Decoder.

COUNTERS AND PROM CONTROL CIRCUIT

Three decimal counters are employed as pulse counters, two counting the tone generator pulses (U10 and U11) and one counting the tone receiver pulses (U12). The counter outputs connect to the PROM inputs and control its output.

Determined by the clock generator period the counter outputs of U10 and U11 will be applied to the PROM inputs causing the PROM to feed the following information to the Tone Board.

$Q_0-Q_1-Q_2-Q_3$ - data to the 4-to-16 Bit Decoder

Inhibit to the 4-to-16 Bit Decoder

Prolonged tone control signal

Tri-state Buffer control data
(variable tones)

For details on coding of the PROM refer to Coding and Strapping.

The 1st PROM input is connected to the 3rd output on the 1st tone transmitter pulse counter, U10, and the result is that a period of 220 ms for the TQ5004, or 320 ms for the TQ5005, elapses before generation of the 1st tone is started. This period corresponds to the length of the three leading clocks pulses. The following five clockpulses generate the tone sequence and on the 8th pulse one of the following events happens:

- 1) A TT reset pulse to the Tone Board will be sent through b (D25) if the unit is strapped to only one sequence; the Q8 output of Counter U10 is logic "1".
- 2) A second sequence with 3 leading clock pulses without tone generation and 5 tones will be generated if the unit is strapped to transmit two sequences; the Q8 output of U10 will enable the 2nd tone transmitter counter U11. A TT reset pulse will be sent to the Tone Board by the Q8 output of U11 when the 16th clock pulse appears.

The Reset inputs of the Counters U10 and U11 are controlled by the \bar{Q} -output of U104a and therefore the Counters are inhibited in standby and not released until the TONE KEY button is depressed.

Counter U12 controls the receiver inputs of the PROM. The counter's control signals are derived from the Clock Delay U101b and the Clear Delay U101d respectively.

In standby the counter is inhibited by the Clear Delay U101d and the counter's "0" output is logic "1". This selects the code of the 1st receiver tone in the PROM.

The operation of the Counter U12 is similar to that of U10 and U11, the clock pulse period being linked to the length of the received tones.

Approximately 120 ms after the last tone has ended the tone receiver counter is reset to standby by the Clear Delay U101d.

All outputs (Q_0 - Q_5) on Counter U12 are accessible on the p.c.b. for setting the individual combination and the Group Call/All Call combination. Refer to Coding and Strapping for details.

Inverter U7b is, together with the counter's enable input, controlled by the U104a's Q-output which in standby is logic "0". When the TONE KEY is depressed a logic 1 is placed on the enable input of U12 and at the same time at the inverter U7b. The inverter output then shorts the counter's "0" output to ground through diode D18.

The times elapsing to transmit or receive a 5-tone sequential signal appear from the Time-Pulse diagrams.

If only one transmitter sequence is required diode b (D25) causes "TT reset" after the first transmitter code has been generated and the TQ5004/TQ5005 reverts to standby in the receive mode.

In the transmission mode is input TT= "1" and input TR= "0", and this ensures that the Receiver Counter U12 is disabled and the reset signals on the Transmitter counters U10

and U11 are removed. The opposite conditions occur when the TQ5004/TQ5005 is in the receive mode.

ACKNOWLEDGE TRANSMISSION

When acknowledge transmission is required, the diodes c, d, and e are inserted. In the receive mode the D-Flip-Flop U9 is "reset" and the diodes are off (reverse biased). After a tone call has been accepted output Q_5 on U12 goes logic "1", turns the loudspeaker on, sets Latch U104a which keys the transmitter, and provides a clock pulse for Flip-Flop U9. This toggles U9 and its Q-output goes logic "1" and \bar{Q} logic "0", and the diodes c, d, and e are turned on. Diode c resets the two Transmitter Counters U10 and U11, diode d enables the Receiver Counter U12, and diode e prevents the "TR-reset" level from resetting the Receiver Counter.

When Latch U104a is "set", the TT input to the Logic Board is logic "1" and input TR is logic "0", but due to the diodes this has no influence on the status of the transmitter and receiver counters. Three clock pulses after the Q_5 output of U12 has been logic "1" the Receiver Counter is reset by diode D22 and the counter is now acting as a tone transmitter counter, transmitting the receiver tone code.

After the last tone has been transmitted a clock pulse toggles Flip-Flop U9 and sets Q logic "0" and \bar{Q} logic "1". This causes an "End of TT" pulse to be sent through diode D21 to reset Latch U104a, and at the same time the diodes c, d, and e are turned off (reverse biased).

Now the TT input is logic "0" and the TR input is logic "1" ensuring that the transmitter Counters U10 and U11 are reset and the Receiver Counter U12 is enabled and reset by the "TR reset".

The TQ5004/TQ5005 is now back in the normal tone receive mode.

AUTO RECEIPT (ACKNOWLEDGE) TRANSMISSION TQ5004 AND TQ5005

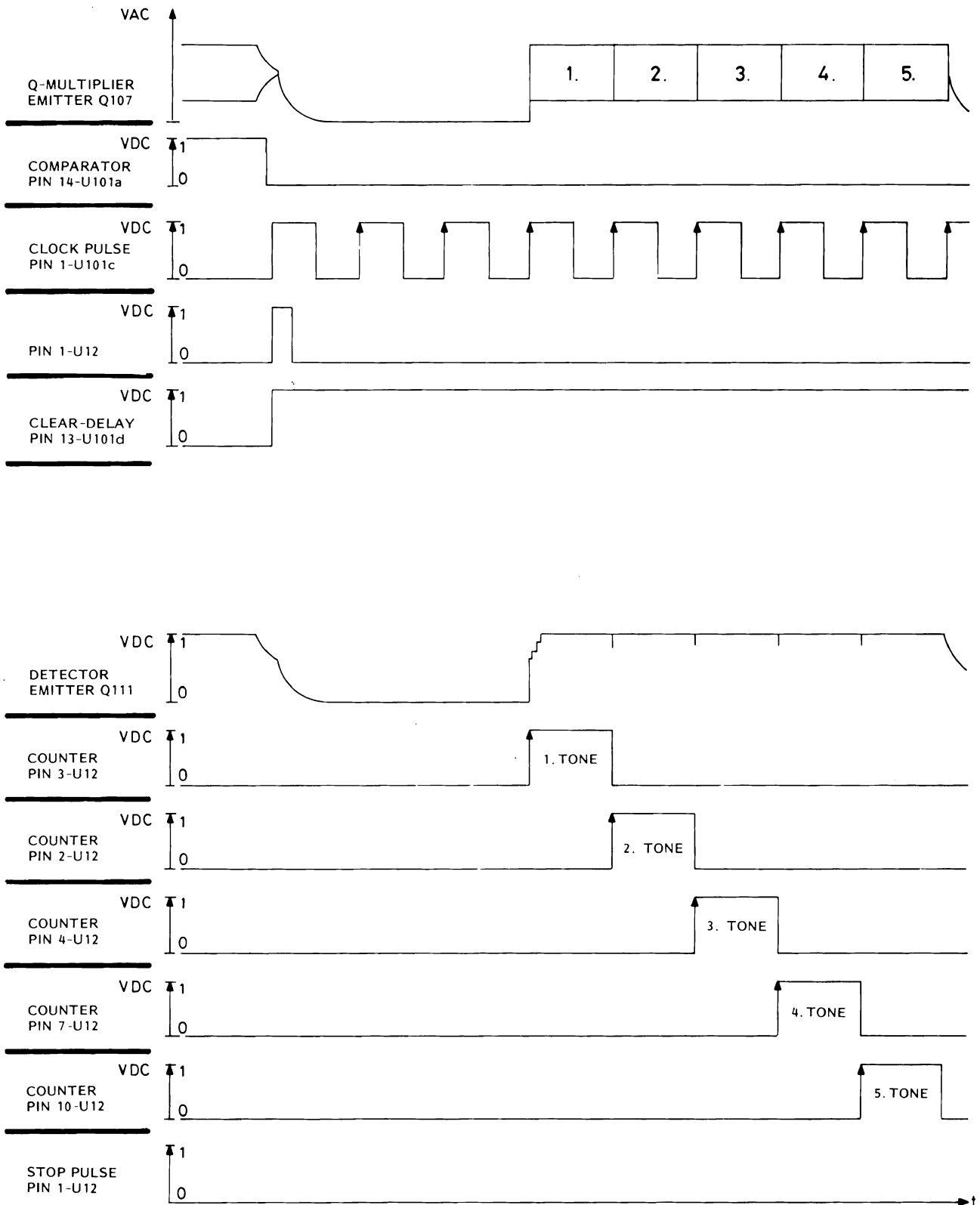

FIG. 13. ACKNOWLEDGE TRANSMISSION

TECHNICAL SPECIFICATIONS

SPECIFICATIONS COMMON TO TQ5004 AND TQ5005

Supply Voltage

8.5 V \pm 0.25 V (8.5 V Cont. and 8.5 V TX)

Current Drain

Standby: <20 mA

Engaged: 20 mA +25 mA peak
when the CALL indicator is on.

Temperature Range

-30°C to +60°C

SEQUENTIAL TONE TRANSMITTER

Signal Output Level

Max. 600 mV EMF (Adjustable)

Frequency Response

Flat \pm 1 dB

Signal Distortion

<5%

Tone Frequency Accuracy

Max. deviation: 1.4%

Rel. freq. accuracy: 0.3%

Adj. accuracy: 0.1%

Freq. stability: 1%

Control Functions

Acknowledge: Can be strapped to automatic transmission of "Acknowledge" after a CALL.

Microphone inhibit

The supply voltage to the microphone amplifier is inhibited when transmitting a tone call.

SEQUENTIAL TONE RECEIVER

Input Impedance

>30 Kohm, DC isolation

Reset Time (T)

90 ms <T <140 ms

Reaction Time (T)

20 ms <T <45 ms

Signal to Noise Conditions

Signal tone receiver will accept signals with a noise level corresponding to SINAD= 5 dB as measured in the speech channel of the CQM5000.

Input Frequency Response

Deemphasis according to an RC function with
 $F_c = 2900$ Hz

Activating Input Level

300 mV \pm 6 dB

Input Signal Distortion

The unit can process tone signals containing up to 20% distortion.

Tone Frequency Accuracy

\pm 0.3%

Tone Frequency Selectivity

The tone receiver is not sensitive to adjacent tones or other tones of the same standard series.

Output Functions

A call produces the following output signals:

- 1) The green LED (D107) will start flashing
- 2) Cancel the short circuit of terminal 4
- 3) Short circuit terminals 2-3

Manual activation of the LS IN/OUT button establishes the same functions.

Switching the loudspeaker off produces the following output signals:

- 1) The green LED (D107) will stop flashing
- 2) RX mute on; short circuit terminal 4 to ground.
- 3) Key blocking on; the connections between terminal 2 and 3 is cancelled.

Dimensions

159.8 mm x 69 mm x 22.5 mm (L x W x H)

Weight

150 g

SPECIFICATIONS UNIQUE TO TQ5004

SEQUENTIAL TONE TRANSMITTER

Output Signal

3, 4, or 5 tones in bursts of 70 ms \pm 15 ms.
The interval between triggering and emission of the 1st tone is min. 200 ms.
Up to 4 tones can be variable and selected from the Key Board.

Tone Frequencies

The ZVEI series:

885 Hz, 970 Hz, 1060 Hz, 1160 Hz, 1270 Hz,
1400 Hz, 1530 Hz, 1670 Hz, 1830 Hz, 2000 Hz,
2200 Hz, 2400 Hz, 2600 Hz, 2800 Hz.

Automatic RF Transmitter Keying

The TQ5004 energizes the RF transmitter for approximately 570 ms.

SEQUENTIAL TONE RECEIVER

Signalling Code

3, 4, or 5 tone bursts of min. 55 ms duration.

Tone Frequencies

The ZVEI series (refer to Sequential Tone Transmitter).

SPECIFICATIONS UNIQUE TO TQ5005

SEQUENTIAL TONE TRANSMITTER

Output Signal

3, 4, or 5 tones in bursts of 100 ms \pm 15 ms.
The interval between triggering and emission of the 1st tone is min. 300 ms.
Up to 4 tones can be variable and selected from the Key Board.

Tone Frequencies

The CCIR series:

(960 Hz, 1022 Hz), 1124 Hz, 1197 Hz, 1275 Hz,
1358 Hz, 1446 Hz, 1540 Hz, 1640 Hz, 1747 Hz,
1860 Hz, 1981 Hz, 2110 Hz.

Automatic RF Transmitter Keying

The TQ5005 energizes the transmitter for approximately 800 ms.

SEQUENTIAL TONE RECEIVER

Signalling Code

3, 4, or 5 tone bursts of min 55 ms duration

Tone Frequencies

The CCIR series (refer to sequential Tone Transmitter).

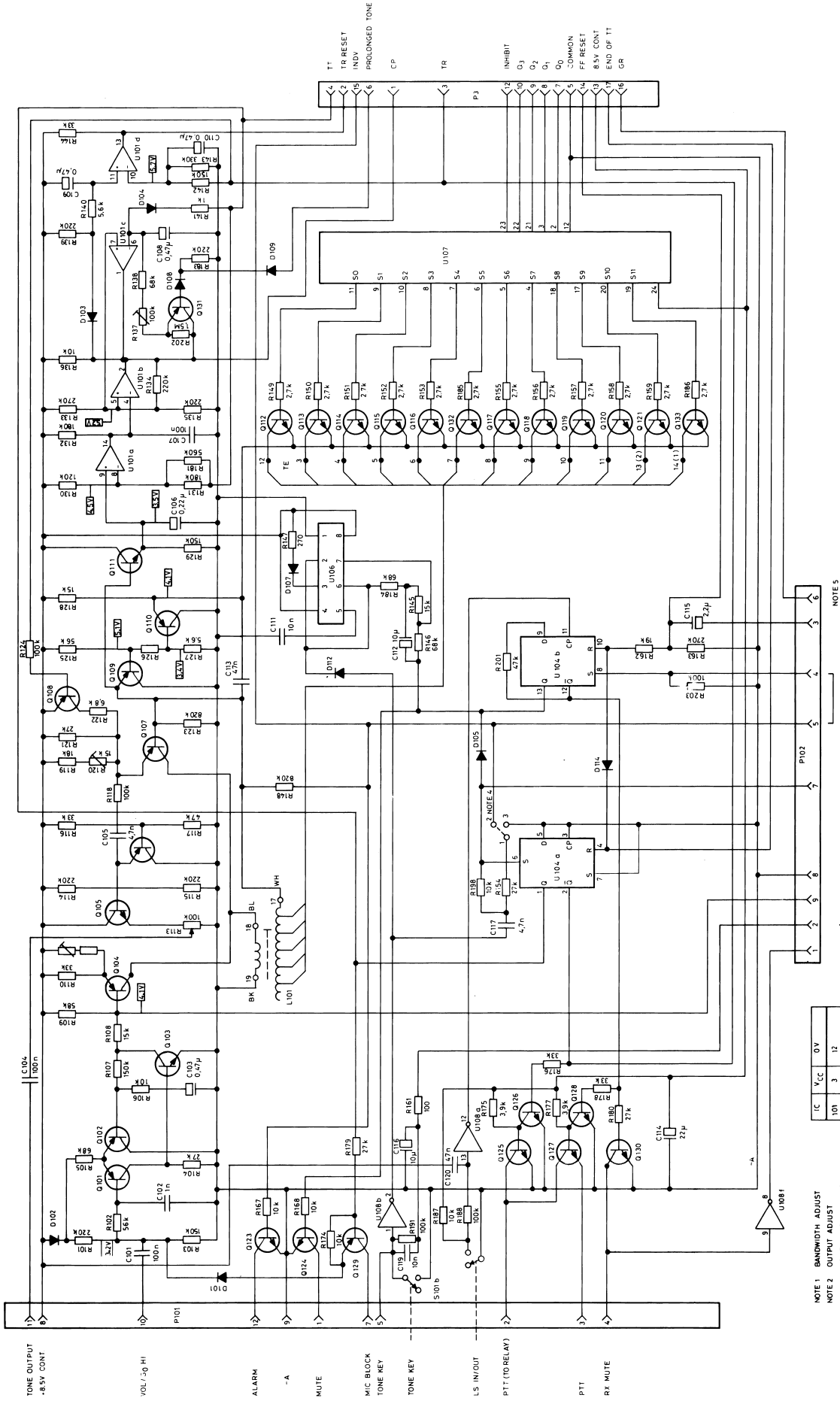

SEQUENTIAL TONE UNIT
TQ5004 AND TQ5005
TONE BOARD

D402. 848 / 2

IC	V _{CC}	0V
101	3	12
104	14	7
106	4-8	1
107	14	7
108	4-8	1

- NOTE 1 BANDWIDTH ADJUST
- NOTE 2 OUTPUT ADJUST
- NOTE 3 TONELENGTH ADJUST
- NOTE 4 SHORT 1-2 FOR AUTO RECEIPT
- NOTE 5 SHORT 1-3 FOR NORMAL MODE
- NOTE 6 SHORT 2-3 AND 4-5 WITHOUT SU5001 OR SU5002

NOTES

PH02

PH03

PH04

PH05

PH06

PH07

PH08

PH09

PH10

PH11

PH12

PH13

PH14

PH15

PH16

PH17

PH18

PH19

PH20

PH21

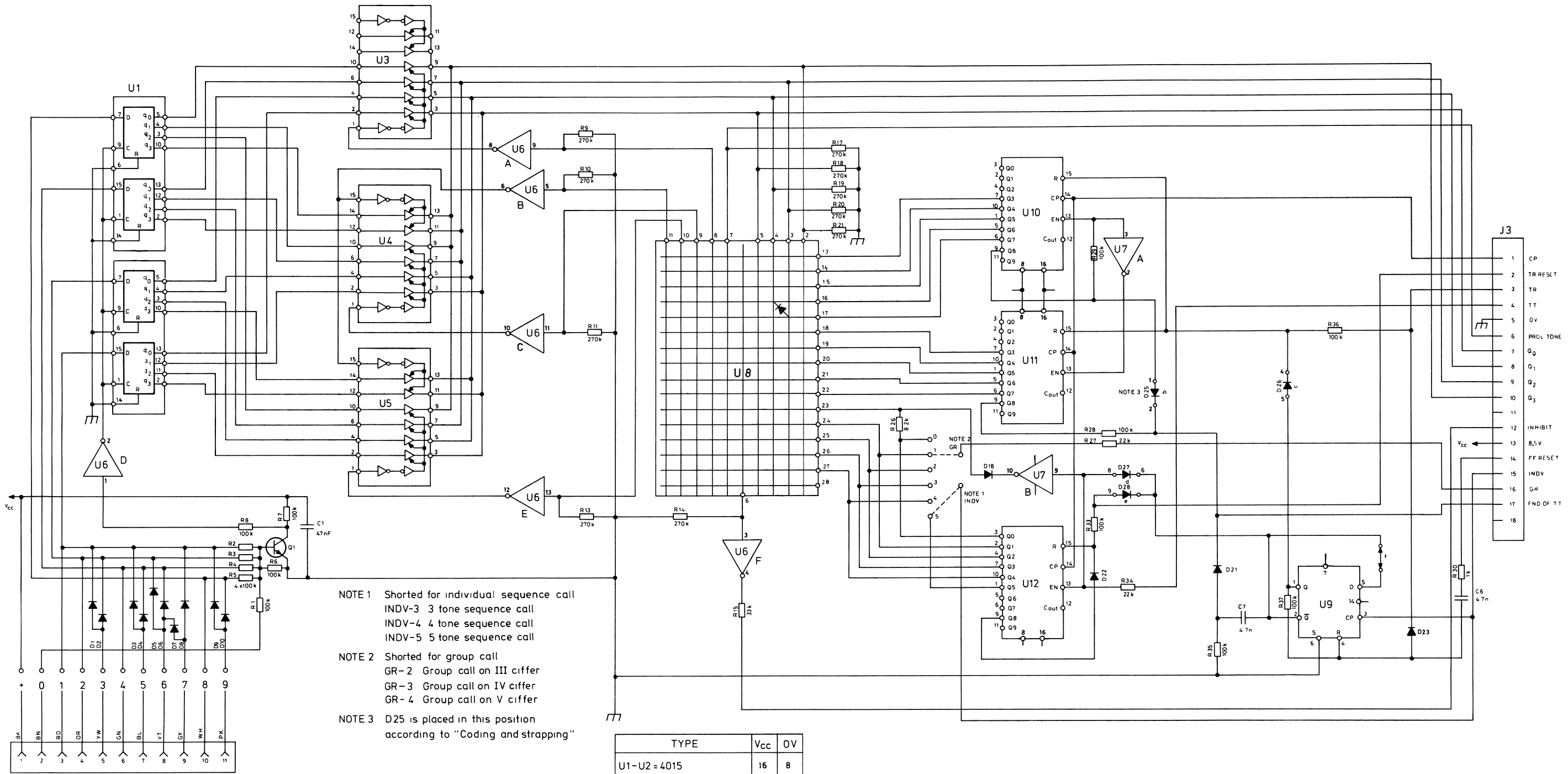

- NOTE 1 Shorted for individual sequence call
 INDV-3 3 tone sequence call
 INDV-4 4 tone sequence call
 INDV-5 5 tone sequence call
- NOTE 2 Shorted for group call
 GR-2 Group call on III ciffer
 GR-3 Group call on IV ciffer
 GR-4 Group call on V ciffer
- NOTE 3 D25 is placed in this position according to "Coding and strapping"

TYPE	Vcc	OV
U1-U2 = 4015	16	8
U3-U4-U5 = 40097	16	8
U6 = 40106	14	7
U7 = 4049	1	8
U8 = PROM	-	1
U9 = 4013	14	7
U10 } U11 } U12 }	16	8

SEQUENTIAL TONE UNIT
 TQ5004 AND TQ5005
 LOGIC BOARD

Storno

Storno

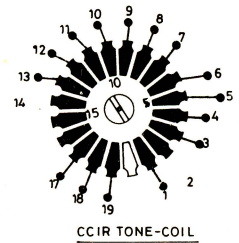
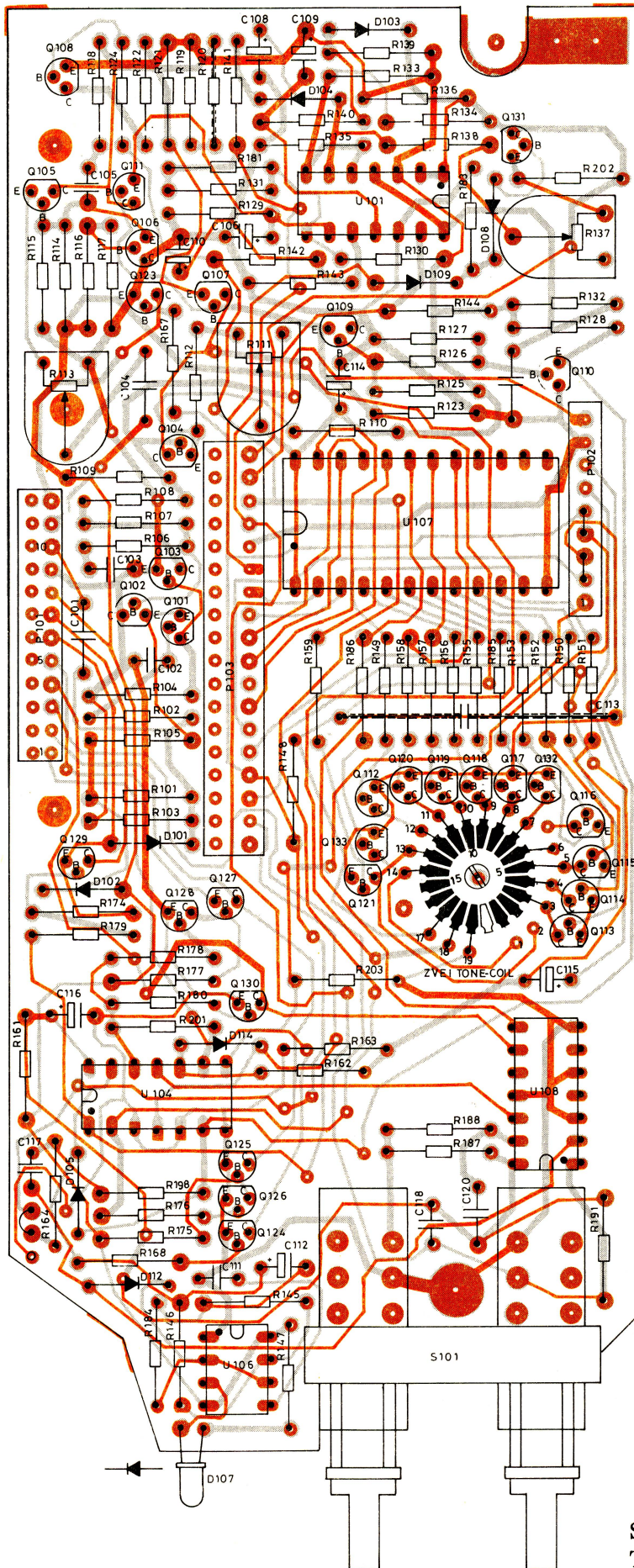

SEQUENTIAL TONE UNIT
TQ5004 AND TQ5005
TONE BOARD

D402. 831/2

Storno

Storno

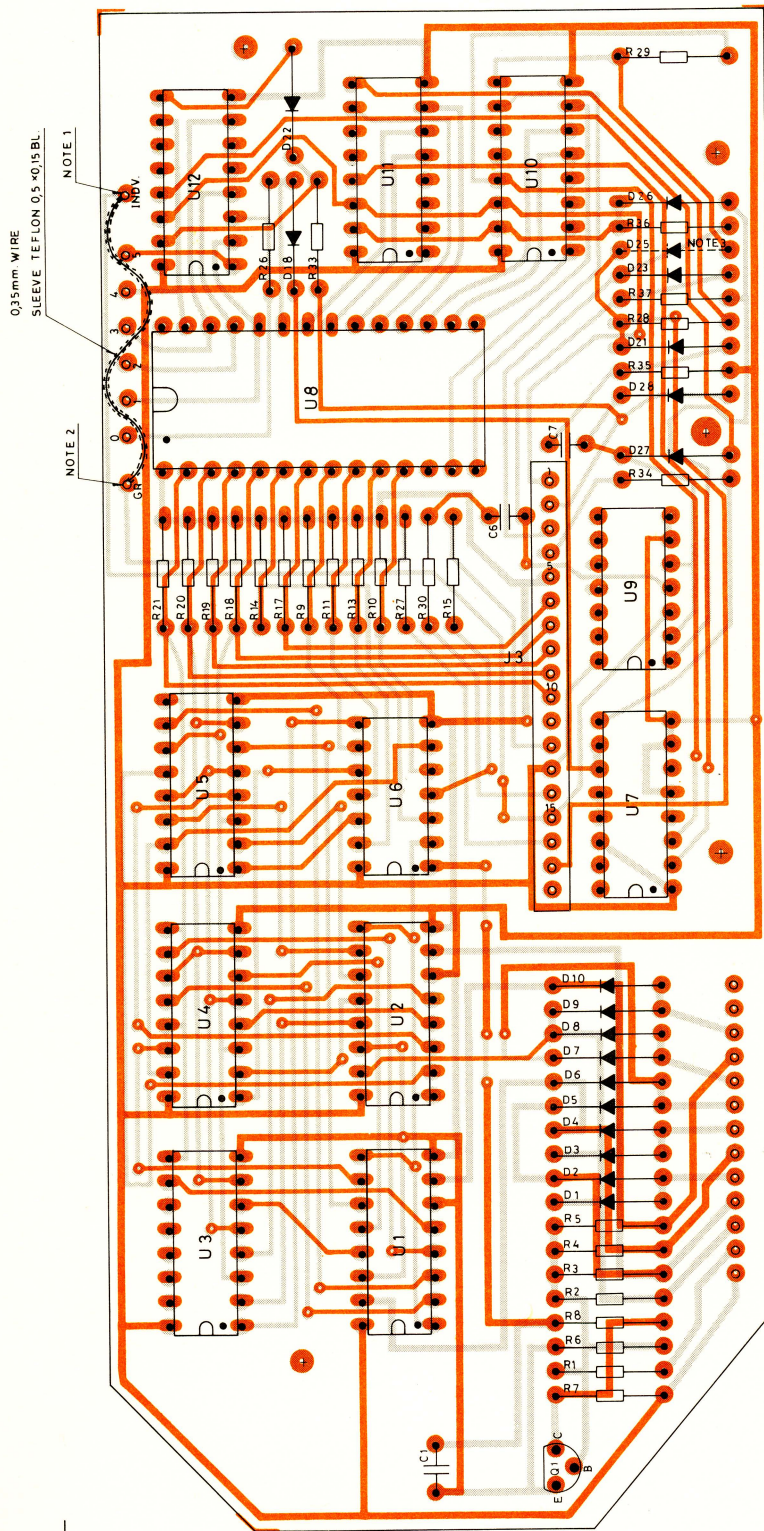

0.35mm WIRE
SLEEVE TEFLON 0.5 x 0.15 BL

NOTE 1

NOTE 2

NOTE 1: Shorted for individual call:
INDV. -3 : 3 Tone sequence call
INDV. -4 : 4 Tone sequence call
INDV. -5 : 5 Tone sequence call

NOTE 2: Shorted for group call
GR. -2 : Group call on III ciffer
GR. -3 : Group call on IV ciffer
GR. -4 : Group call on V ciffer

NOTE 3: D25 IS mounted in this position
according to "coding and strapping"

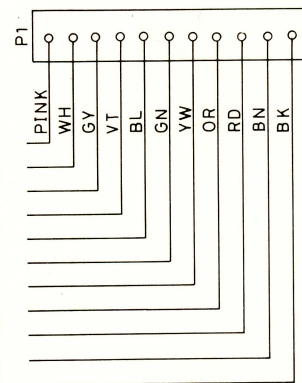

SEQUENTIAL TONE UNIT
TQ5004 AND TQ5005
LOGIC BOARD

D402. 832/2

TYPE	Nº	CODE	DATA
	C 1	76. 5139	47 nF 10% Polyester FL
	C 6	76. 5133	4. 7 nF 10% Polyester FL
	C 7	76. 5133	4. 7 nF 10% Polyester FL
	C101	76. 5144	0. 1 uF 10% Polyester FL
	C102	76. 5129	1 nF 10% Polyester FL
	C103	73. 5169	0. 47 uF 20% Tantal
	C104	76. 5144	0. 1 uF 10% Polyester FL
	C105	76. 5133	4. 7 nF 10% Polyester FL
	C106	73. 5168	0. 22 uF 20% Tantal
	C107	76. 5144	0. 1 uF 10% Polyester FL
	C108	73. 5170	1. 0 uF 20% Tantal
	C109	73. 5169	0. 47 uF 20% Tantal
	C110	73. 5169	0. 47 uF 20% Tantal
	C111	76. 5135	10 nF 10% Polyester FL
	C112	73. 5173	10 uF 20% Tantal
	C113	76. 5123	47 nF 2. 5% Polyester TB
	C114	73. 5174	22 uF 20% Tantal
	C115	73. 5171	2. 2 uF 20% Tantal
	C116	73. 5173	10 uF 20% Tantal
	C117	76. 5133	4. 7 nF 10% Polyester FL
	C118	76. 5135	10 nF 10% Polyester FL
	C120	76. 5139	47 nF 10% Polyester FL
	D 1	99. 5237	1N4148 Diode
	D 2	99. 5237	1N4148 Diode
	D 3	99. 5237	1N4148 Diode
	D 4	99. 5237	1N4148 Diode
	D 5	99. 5237	1N4148 Diode
	D 6	99. 5237	1N4148 Diode
	D 7	99. 5237	1N4148 Diode
	D 8	99. 5237	1N4148 Diode
	D 9	99. 5237	1N4148 Diode
	D 10	99. 5237	1N4148 Diode
	D 18	99. 5137	1N4148 Diode
	D 21	99. 5237	1N4148 Diode
	D 22	99. 5237	1N4148 Diode
	D 23	99. 5237	1N4148 Diode
	D 25	99. 5237	1N4148 Diode
	D 26	99. 5237	1N4148 Diode
	D 27	99. 5237	1N4148 Diode
	D 28	99. 5237	1N4148 Diode
	D101	99. 5237	1N4148 Diode
	D102	99. 5237	1N4148 Diode
	D103	99. 5237	1N4148 Diode
	D104	99. 5237	1N4148 Diode
	D105	99. 5237	1N4148 Diode
	D107	99. 5325	LED Yellow
	D108	99. 5237	1N4148 Diode

TYPE	Nº	CODE	DATA
TQ5004	D109	99. 5237	1N4148 Diode
TQ5005	D112	99. 5237	1N4148 Diode
	D114	99. 5237	1N4148 Diode
	J 3	41. 5568	Male Connector
	L101	61. 1421	Tone coil ZVEI
	L101	61. 1422	Tone coil CCIR
	P 1	41. 5570	PROM socket
	P101	41. 5549	Female connector
	P102	41. 5548	Female connector
	P103	41. 5569	Female connector
	Q 1	99. 5121	BC237 Transistor
	Q101	99. 5230	BC308 Transistor
	Q102	99. 5230	BC308 Transistor
	Q103	99. 5143	BC238 Transistor
	Q104	99. 5230	BC308 Transistor
	Q105	99. 5143	BC238 Transistor
	Q106	99. 5230	BC308 Transistor
	Q107	99. 5115	BC309 Transistor
	Q108	99. 5230	BC308 Transistor
	Q109	99. 5230	BC308 Transistor
	Q110	99. 5230	BC308 Transistor
	Q111	99. 5143	BC238 Transistor
	Q112	99. 5324	BC338 Transistor
	Q113	99. 5324	BC338 Transistor
	Q114	99. 5324	BC338 Transistor
	Q115	99. 5324	BC338 Transistor
	Q116	99. 5324	BC338 Transistor
	Q117	99. 5324	BC338 Transistor
	Q118	99. 5324	BC338 Transistor
	Q119	99. 5324	BC338 Transistor
	Q120	99. 5324	BC338 Transistor
	Q121	99. 5324	BC338 Transistor
	Q123	99. 5143	BC238 Transistor
	Q124	99. 5143	BC238 Transistor
	Q125	99. 5143	BC238 Transistor
	Q126	99. 5143	BC238 Transistor
	Q127	99. 5143	BC238 Transistor
	Q128	99. 5143	BC238 Transistor
	Q129	99. 5230	BC308 Transistor
	Q130	99. 5143	BC238 Transistor
	Q131	99. 5115	BC309 Transistor
	Q132	99. 5324	BC338 Transistor

SEQUENTIAL TONE UNIT TQ5004, TQ5005

X402. 810

TYPE	Nº	CODE	DATA
	Q133	99. 5324	BC338 Transistor
	R 1	80. 5273	100 Kohm 5% Carbon film
	R 2	80. 5273	100 Kohm 5% Carbon film
	R 3	80. 5273	100 Kohm 5% Carbon film
	R 4	80. 5273	100 Kohm 5% Carbon film
	R 5	80. 5273	100 Kohm 5% Carbon film
	R 6	80. 5273	100 Kohm 5% Carbon film
	R 7	80. 5261	10 Kohm 5% Carbon film
	R 8	80. 5273	100 Kohm 5% Carbon film
	R 9	80. 5278	270 Kohm 5% Carbon film
	R 10	80. 5278	270 Kohm 5% Carbon film
	R 11	80. 5278	270 Kohm 5% Carbon film
	R 13	80. 5278	270 Kohm 5% Carbon film
	R 14	80. 5278	270 Kohm 5% Carbon film
	R 15	80. 5267	33 Kohm 5% Carbon film
	R 17	80. 5278	270 Kohm 5% Carbon film
	R 18	80. 5278	270 Kohm 5% Carbon film
	R 19	80. 5278	270 Kohm 5% Carbon film
	R 20	80. 5278	270 Kohm 5% Carbon film
	R 21	80. 5278	270 Kohm 5% Carbon film
	R 26	80. 5260	8.2 Kohm 5% Carbon film
	R 27	80. 5265	22 Kohm 5% Carbon film
	R 28	80. 5273	100 Kohm 5% Carbon film
	R 29	80. 5273	100 Kohm 5% Carbon film
	R 30	80. 5249	1 Kohm 5% Carbon film
	R 33	80. 5273	100 Kohm 5% Carbon film
	R 34	80. 5265	22 Kohm 5% Carbon film
	R 35	80. 5273	100 Kohm 5% Carbon film
	R 36	80. 5273	100 Kohm 5% Carbon film
	R 37	80. 5273	100 Kohm 5% Carbon film
	R101	80. 5277	220 Kohm 5% Carbon film
	R102	80. 5270	56 Kohm 5% Carbon film
	R103	80. 5275	150 Kohm 5% Carbon film
	R104	80. 5266	27 Kohm 5% Carbon film
	R105	80. 5271	68 Kohm 5% Carbon film
	R106	80. 5261	10 Kohm 5% Carbon film
	R107	80. 5275	150 Kohm 5% Carbon film
	R108	80. 5263	15 Kohm 5% Carbon film
	R109	80. 5271	68 Kohm 5% Carbon film
	R110	80. 5267	33 Kohm 5% Carbon film
	R111	86. 5036	47 Kohm 20% Trim carbon
	R112	80. 5261	10 Kohm 5% Carbon film
	R113	86. 5074	100 Kohm 20% Trim carbon
	R114	80. 5277	220 Kohm 5% Carbon film
	R115	80. 5277	220 Kohm 5% Carbon film
	R116	80. 5267	33 Kohm 5% Carbon film
	R117	80. 5269	47 Kohm 5% Carbon film

TYPE	Nº	CODE	DATA
	R118	80. 5273	100 Kohm 5% Carbon film
	R119	80. 5264	18 Kohm 5% Carbon film
	R120	89. 5010	15 Kohm 20% NTC
	R121	80. 5266	27 Kohm 5% Carbon film
	R122	80. 5259	6.8 Kohm 5% Carbon film
	R123	80. 5284	820 Kohm 5% Carbon film
	R124	80. 5273	100 Kohm 5% Carbon film
	R125	80. 5258	5.6 Kohm 5% Carbon film
	R126	80. 5254	2.7 Kohm 5% Carbon film
	R127	80. 5258	5.6 Kohm 5% Carbon film
	R128	80. 5263	15 Kohm 5% Carbon film
	R129	80. 5275	150 Kohm 5% Carbon film
	R130	80. 5274	120 Kohm 5% Carbon film
	R131	80. 5276	180 Kohm 5% Carbon film
	R132	80. 5276	180 Kohm 5% Carbon film
	R133	80. 5278	270 Kohm 5% Carbon film
	R134	80. 5277	220 Kohm 5% Carbon film
	R135	80. 5277	220 Kohm 5% Carbon film
	R136	80. 5261	10 Kohm 5% Carbon film
	R137	86. 5074	100 Kohm 20% Trim carbon
	R138	80. 5266	27 Kohm 5% Carbon film
	R139	80. 5277	220 Kohm 5% Carbon film
	R140	80. 5258	5.6 Kohm 5% Carbon film
	R141	80. 5249	1 Kohm 5% Carbon film
	R142	80. 5275	150 Kohm 5% Carbon film
	R143	80. 5279	330 Kohm 5% Carbon film
	R144	80. 5267	33 Kohm 5% Carbon film
	R145	80. 5263	15 Kohm 5% Carbon film
	R146	80. 5271	68 Kohm 5% Carbon film
	R147	80. 5242	270 ohm 5% Carbon film
	R148	80. 5284	820 Kohm 5% Carbon film
	R149	80. 5254	2.7 Kohm 5% Carbon film
	R150	80. 5254	2.7 Kohm 5% Carbon film
	R151	80. 5254	2.7 Kohm 5% Carbon film
	R152	80. 5254	2.7 Kohm 5% Carbon film
	R153	80. 5254	2.7 Kohm 5% Carbon film
	R155	80. 5254	2.7 Kohm 5% Carbon film
	R156	80. 5254	2.7 Kohm 5% Carbon film
	R157	80. 5254	2.7 Kohm 5% Carbon film
	R158	80. 5254	2.7 Kohm 5% Carbon film
	R159	80. 5254	2.7 Kohm 5% Carbon film
	R161	80. 5237	100 ohm 5% Carbon film

SEQUENTIAL TONE UNIT TQ5004, TQ5005

X402. 810

TYPE	Nº	CODE	DATA
	R162	80. 5261	10 Kohm 5% Carbon film
	R163	80. 5278	270 Kohm 5% Carbon film
	R164	80. 5266	27 Kohm 5% Carbon film
	R167	80. 5261	10 Kohm 5% Carbon film
	R168	80. 5261	10 Kohm 5% Carbon film
	R174	80. 5261	10 Kohm 5% Carbon film
	R175	80. 5256	3.9 Kohm 5% Carbon film
	R176	80. 5267	33 Kohm 5% Carbon film
	R177	80. 5256	3.9 Kohm 5% Carbon film
	R178	80. 5267	33 Kohm 5% Carbon film
	R179	80. 5266	27 Kohm 5% Carbon film
	R180	80. 5266	27 Kohm 5% Carbon film
	R181	80. 5282	560 Kohm 5% Carbon film
	R183	80. 5277	220 Kohm 5% Carbon film
	R184	80. 5271	68 Kohm 5% Carbon film
	R185	80. 5254	2.7 Kohm 5% Carbon film
	R186	80. 5254	2.7 Kohm 5% Carbon film
	R187	80. 5261	10 Kohm 5% Carbon film
	R188	80. 5273	100 Kohm 5% Carbon film
	R191	80. 5273	100 Kohm 5% Carbon film
	R198	80. 5261	10 Kohm 5% Carbon film
	R201	80. 5269	47 Kohm 5% Carbon film
	R202	80. 5287	1.5 Mohm 5% Carbon film
	R203	80. 5273	100 Kohm 5% Carbon film
	S101	47. 0642	Switch assembly
	U 1	14. 5091	CD4015 Shift reg.
	U 2	14. 5091	CD4015 Shift reg.
	U 3	14. 5117	CD40097 Hex buffer F
	U 4	14. 5117	CD40097 Hex buffer F
	U 5	14. 5117	CD40097 Hex buffer F
	U 6	14. 5146	CD40106 Hex inverter
	U 7	14. 5049	CD4049 Hex inverter
	U 8	14. 5147	SO353 PROM
	U 9	14. 5098-01	CD4013 Dual D-FF
	U 10	14. 5052-01	CD4017B Johnson Counter
	U 11	14. 5052-01	CD4017B Johnson Counter
	U 12	14. 5052-01	CD4017B Johnson Counter
	U101	14. 5019	MC3302P Quad comparator
	U104	14. 5098-01	CD4013B Dual D-FF
	U106	14. 5134	555 Timer
	U107	14. 5145	4514B Encoder
	U108	14. 5146	CD40106B Hex Schmitt trigger

SEQUENTIAL TONE UNIT TQ5004, TQ5005

X402. 810

CODING AND STRAPPING INSTRUCTION

TQ5004 AND TQ5005

GENERAL

When coding and strapping a TQ5004 or TQ5005 module, and programming its PROM circuit, the following decisions must be made:

1. One or two transmitter sequences (Logic Board).
2. First transmitter sequence (PROM).
 - a. Number of tones (3, 4, or 5).
 - b. Frequencies of fixed tones (Table 1).
 - c. Variable tones.
 - d. Prolongation of first tone.
3. Second transmitter sequence (PROM).
 - a. Number of tones (3, 4, or 5).
 - b. Frequencies of fixed tones (Table 1).
 - c. Variable tones.
 - d. Prolongation of first tone.
4. The tone receiver sequence (PROM).
 - a. Number of tones (3, 4, or 5).
 - b. Frequencies of the tones.
5. Group Call (Logic Board).
 - a. Group tone format.
 - b. Frequency of group call tone (SU5001).
6. All Call (Logic Board).
 - a. Frequency of all call tone (SU5002).
7. Auto Receipt (Acknowledge) (Tone Board).
 - a. Transmitter sequence acknowledge (Logic Board).
 - b. Receiver sequence acknowledge (Logic Board).

These data are used to complete the words of addresses 1 to 5 on the PROM Code Specification Chart, fig. 1.

3. Second transmitter sequence (PROM).
 - a. Number of tones (3, 4, or 5).
 - b. Frequencies of fixed tones (Table 1).
 - c. Variable tones.
 - d. Prolongation of first tone.

These data are used to complete the words of addresses 6 to 10 on the PROM Code Specification Chart, fig. 1.

NOTE: Maximum 4 variable tones can be inserted in the two transmitter sequences. See also Tone Format.

4. The tone receiver sequence (PROM).
 - a. Number of tones (3, 4, or 5).
 - b. Frequencies of the tones.

These data are used to complete the words of addresses 11 to 15 on the Code Specification Chart, fig. 1.

The tone transmitter codes and the tone receiver code are independent of each other and examples are given separately.

The tone format, 1 or 2 tone transmitter codes, automatic receipt (acknowledge), and group call options are all coded by a strapping and diode arrangement on the printed wiring board.

TONE FORMATS

The need for insertion of repeat tones will in some applications limit the number of selectable calls, but anyhow, the R-tone (repeat) can be used as a fixed tone in a code. The coding possibilities and their limitations are shown below.

TONE FORMATS FOR TRANSMITTED TONE CALLS

FORMAT 1.

- Transmission of one sequential tone signal.

1	2	3	4	5
---	---	---	---	---

Standard 5 tone sequence.

												Total number of variables in system	
BIT	9	8	7	6	5	4	3	2	1	0			
A D D R E S S	TQ5004 TQ5005 PROM CODE SPECIFICATION	TONE FREQUENCY BIT Q ₃	TONE FREQUENCY BIT Q ₂	TONE FREQUENCY BIT Q ₁	TONE FREQUENCY BIT Q ₀	INHIBIT BIT	PROLONGED TONE BIT	V ₁				1 Variable	
								V ₂	V ₁			2 Variables	
								V ₃	V ₂	V ₁			3 Variables
								V ₄	V ₃	V ₂	V ₁		4 Variables
VARIABLE TONE	VARIABLE TONE	VARIABLE TONE	VARIABLE TONE										
1	ST1-1. TONE												
2	ST1-2. TONE												
3	ST1-3. TONE												
4	ST1-4. TONE												
5	ST1-5. TONE												
6	ST2-1. TONE												
7	ST2-2. TONE												
8	ST2-3. TONE												
9	ST2-4. TONE												
10	ST2-5. TONE												
11	SR-1. TONE												
12	SR-2. TONE												
13	SR-3. TONE												
14	SR-4. TONE												
15	SR-5. TONE												
16	SPARE												

FIG. 1
PROM Code Specification Chart

Prolonged tone: Bit 4 = 1
Tone inhibit: Bit 5 = 0

Fused diode = 0

PROM Code Specification Chart.

R= Repeat tone.

V_x = Variable tone (x).

ST1= Sequential Tone Transmit 1.

ST2= Sequential Tone Transmit 2.

SR= Sequential Tone Receive.

EX. A

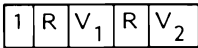

No limitation in the variable digits V₁ and V₂.
 R= repeat tone.
 100 CALLS.

EX. B

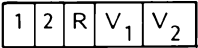

Limitation, V₁ cannot be selected equal to V₂.
 90 CALLS.

EX. C

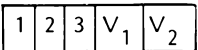

Limitation, V₁ cannot be selected equal to V₂ and V₁ cannot be selected equal to 3.
 81 CALLS.

EX. D

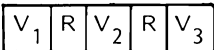

No limitations in the variable digits, V₁, V₂ and V₃. R= repeat tone.
 1000 CALLS.

EX. E

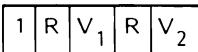

No limitation in the variable digits V₁ and V₂.
 Prolonged 1st-tone max 1.2 sec.

FORMAT 2.

- Transmission of two consecutive sequential tone signals.



Same possibilities and limitations rules as for format 1. There is no limitation in selection of last digit in first tone signal and first digit in 2nd tone signal.

EX. A

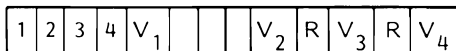

V₁=V₂ is valid.

STRAPPING FOR 3, 4, or 5 TONES

See fig. 2.

Connect a wire from the INDV-terminal as follows:

- INDV to 3 for 3-tone sequential call
- INDV to 4 for 4-tone sequential call
- INDV to 5 for 5-tone sequential call

STRAPPING FOR GROUP CALL OR ALL CALL

The TQ5004/TQ5005 can accommodate a SU5001 (group call) or SU5002 (all call) module designed for receiving one group call or all call tone.

Connect a wire from the GR-terminal as follows:

- GR to 2 for group call on the 3rd tone.
- GR to 3 for group call on the 4th tone.
- GR to 4 for group call on the 5th tone.

GR to 0 for all call.

For code combinations and their limitations see coding for SU5001 and SU5002.

STRAPPING FOR AUTOMATIC RECEIPT (ACKNOWLEDGE)

Tone Board

Short terminal 1-3 for NORMAL mode.
 Short terminal 1-2 for AUTO RECEIPT mode.

Logic Board

Insert diodes c (D26), d (D27) and e (D28) for Auto Receipt (acknowledge) with the tone receiver code.

If none of the diodes are inserted the generated Auto Receipt code will be the tone transmitter code(s).

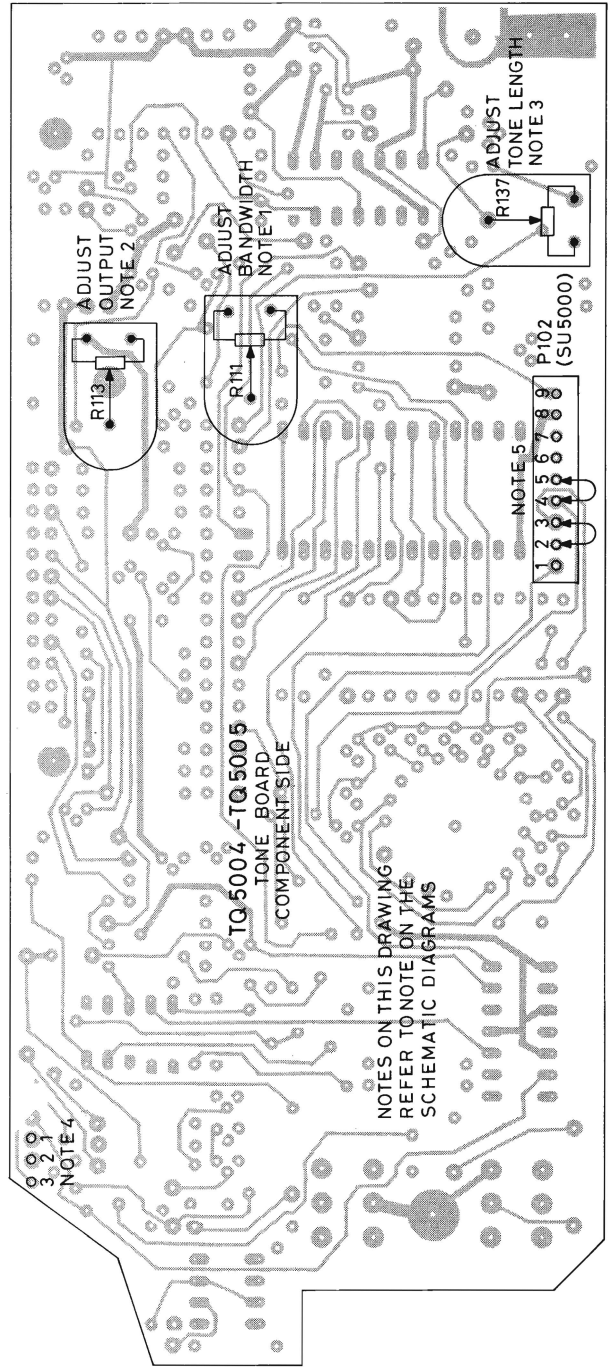
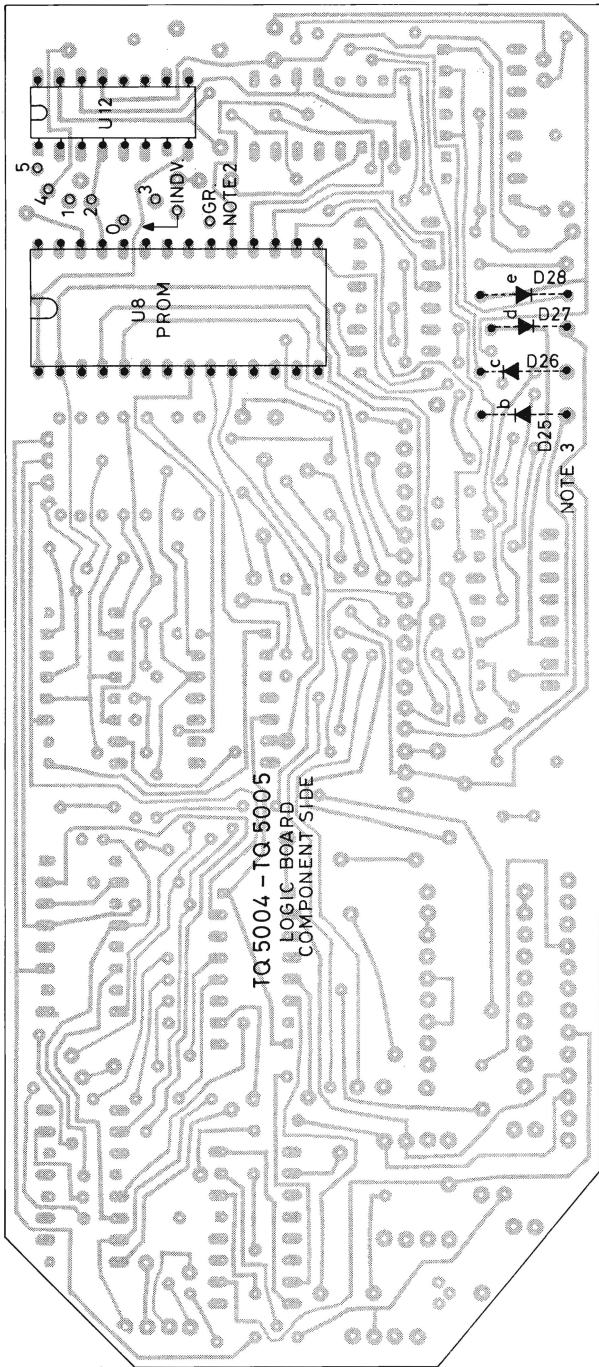

FIG 2. CIRCUIT BOARD LAYOUT TQ5004-TQ5005.

STRAPPING FOR 1-SEQUENCE TRANSMISSION

Logic Board

Insert diode b (D25).

STRAPPING FOR 2-SEQUENCE TRANSMISSION

Logic Board

Omit diode b (D25).

PROM CODE SPECIFICATION

The following list gives the information contained in the PROM circuit:

1. Data for each tone frequency to be transmitted (4 bits).
2. Data for selectable tones (1 of 4 bits).
3. Data for each tone frequency to be received (4 bits).
4. Inhibit to the 4-of-16 bit decoder for each address not used (1 bit).
5. Prolonged length of first tone (1 bit).

The PROM is a diode matrix with 16 addresses each forming a 10 bit word as shown on the PROM Code Specification Chart, fig. 1.

Addresses 1 to 5 are controlled by the first tone transmitter counter (U10).

Addresses 6 to 10 are controlled by the second tone transmitter counter (U11).

Addresses 11 to 15 are controlled by the tone receiver counter (U12).

Address 16 is spare

Bits 6 to 9 are bit data for the 4 to 16 bit decoder.

A fused diode gives bit= "0", otherwise bit= "1".

TONE	Frequency Hz		BIT			
	TQ5004	TQ5005	9	8	7	6
X	885	960	1	0	1	0
Y	970	1022	1	0	1	1
1	1060	1124	0	0	0	1
2	1160	1197	0	0	1	0
3	1270	1275	0	0	1	1
4	1400	1380	0	1	0	0
5	1530	1446	0	1	0	1
6	1670	1540	0	1	1	0
7	1830	1640	0	1	1	1
8	2000	1747	1	0	0	0
9	2200	1860	1	0	0	1
0	2400	1981	0	0	0	0
R	2600	2110	1	0	1	0
A	2800	-	1	0	1	1

Table 1. Tone Frequencies

The X and Y tones replaces the R and A tones in 12.5 kHz channel spacing equipment.

Bit 5 is inhibit data bit for the 4 to 16 bit decoder; a fused diode gives bit= "0", otherwise bit= "1".

To ensure stable operation all diodes on inhibit addresses are blown, i. e. bit= "0". The decoder is inhibited, i. e. the tone not used, if the corresponding inhibit bit is "0".

Bit 4 is prolonged tone data bit for the Clock Pulse Generator. A fused diode gives bit= "0", otherwise bit= "1".

The tone is prolonged, 1.2 second, if the corresponding data bit is "1".

Bit 3 is the fourth variable tone, V_4 .

Bit 2 is the third variable tone, V_3 .

Bit 1 is the second variable tone, V_2 .

Bit 0 is the first variable tone, V_1

A tone is variable when the corresponding data bit= "1".

A fused diode gives data bit= "0", otherwise bit= "1".

BIT	3	2	1	0
4 Variables	V ₄	V ₃	V ₂	V ₁
3 Variables	V ₃	V ₂	V ₁	
2 Variables	V ₂	V ₁		
1 Variables	V ₁			

V_x = Variable tone x

A variable tone is inserted in the code when the bit= 1.

TONE RECEIVER FREQUENCY CODING

The bit pattern of the tone frequencies are programmed on addresses A11 to A15 as shown in table 1.

PROM ADDRESS			5-TONE	4 TONE	3-TONE
A1	A6	A11	1. digit	1. digit	1. digit
A2	A7	A12	2. digit	2. digit	2. digit
A3	A8	A13	3. digit	3. digit	3. digit
A4	A9	A14	4. digit	4. digit	INHIBIT
A5	A10	A15	5. digit	INHIBIT	INHIBIT

PROGRAMMABLE CHANNEL GUARD

TQ5006

The Channel Guard modules TQ5005 are field programmable, synthesized single tone Channel Guard encoders/decoders for use with STORNOPHONE 5000 mobile radios.

The encode function provides continuous tone-coded modulation for the transmitter. The decode function is used with the receiver to eliminate all calls that are not tone coded with the proper Channel Guard (CG) frequency.

A tone reject filter is available for use in non-Channel Guard mobiles and stations that receive tone modulated calls.

Four different Channel Guard boards are available:

TQ5006 - single tone encode/decode (includes tone reject filter).

TT5002 - single tone encode only.

TR5002 - single tone decode only (includes tone reject filter).

FN5002 - tone reject filter only.

OPERATION

In mobile Channel Guard applications, a microphone hookswitch is supplied with the radio.

The CG hookswitch is equipped with a CG disable switch.

Placing the CG switch in the "up" position

(towards the small speaker symbol) disables the receive Channel Guard. With the switch in the "down" position, the receive Channel Guard is disabled when the microphone is removed from the hookswitch.

CIRCUIT DESCRIPTION

Channel Guard is a continuous-tone controlled squelch system that provides communications control in accordance with EIA standard RS-220-A. The basic Channel Guard system utilizes standard tone frequencies from 67 to 210.7 Hz with both the encoder and decoder operating on the same frequency. The standard Channel Guard tone frequencies are shown in the following chart.

STANDARD TONE FREQUENCIES, Hz

67.0				
71.9	88.5	107.2	131.8	162.2
74.4	91.5	110.9	136.5	167.9
77.0	94.8	114.8	141.3	173.8
79.7	97.4	118.8	146.2	179.9
82.5	100.0	123.0	151.4	186.2
85.4	103.5	127.3	156.7	192.8
				203.5
				210.7

The Channel Guard circuitry consists of frequency synthesizer U1003, encoder/decoder U1001, tone programming switch S1001, tone reject (high pass) filter integrated circuit (IC) U1004 and associated discrete circuitry. Frequency synthesizer U1004/U1003 includes the synthesizer IC and a 32.768 Hz reference crystal that provides the clock inputs for the encoder/decoder module (U1001). The clock inputs are required to produce the tone frequency and the digitally generated time delays for the DELAYED PTT and squelch tail elimination (STE) circuits. Tone frequency programming is accomplished by setting the 10 station switch (S1001) for the proper binary input to the synthesizer. The switch can be set to produce any CG tone from 67 Hz to 210.7 Hz in 0.25 Hz increments. Encode/decode hybrid U1001 contains the encoder and decoder, a voice reject filter, STE circuit and the interface circuitry.

The interface circuitry provide:
Increased output drive for RX MUTE, PTT DLYD (Delayed Push-To-Talk) and other functions.

ENCODE MODE

Depressing the PTT switch (Push To Talk) applies a low (A-) to PTT lead P1005-7. This causes the PTT DLYD lead (P1005) to go low, keying the transmitter.

The encoder then generates the CG tone which is applied to a low pass filter to remove any tone or clock harmonics. The filter output is then applied to CG MODULATION control R1004 and CG HI lead (P1005-4) to the transmit audio processor on the transmit/receive (TX/RX) board.

When the PTT button on the microphone is released (transmitter unkeyed), the DELAYED PTT circuit in U1001 keeps the transmitter keyed for an additional 160 milliseconds. During the 160 milliseconds delay time, the encoder shifts the phase of the CG tone output

135°. This combination of 160 milliseconds delay and the 135° phase shift causes the CG decoder in other receivers to squelch the audio before the loss of RF signal, eliminating the receiver noise burst (squelch tail elimination STE).

DECODE MODE

In the receive mode, receiver audio from VOLUME/SQUELCH HI lead P1005-2 is applied to a voltage divider (R1002 and R1003) and then to a voice reject filter in the decode circuit. The filter removes any voice information to prevent blocking or clipping.

The digital decoder compares the frequency of the incoming tone to a reference clock input produced by the synthesizer. If the correct tone is detected, the decoder circuit causes the RX MUTE lead at P1005-9 to go high, un-squelching the receiver. RX MUTE lead P1005-9 is normally held at a low voltage condition when the correct CG tone is not detected.

After the CG tone is decoded, the decoder then waits for a phase shift in the tone to occur. When the phase shift occurs, the STE delay circuit in the decoder pulls the RX MUTE lead to a low voltage state. This squelches the receiver for 200 milliseconds and keeps the receiver squelched until the RF carrier applied to the receiver is removed.

STONE REJECT FILTER

A tone reject filter is connected in parallel with the VOLUME control to attenuate the tone level reaching the receiver audio circuits. The filter consists of operational amplifier U1004 and associated circuitry.

Audio from VOL/SQ HI is connected to the tone reject filter through P1005-2. The filter circuit rejects all tone frequencies from 70 to 210.7 Hz, and passes all other audio frequencies. The filtered and amplified audio is applied to the receiver audio circuits through P1005-1 (FLTRD VOL/SQ HI).

ENCODE DISABLE

The Encode Disable circuit has been incorporated as a maintenance aid for the serviceman. This circuit consists of Q1001, C1010, R1018 and R1019, and can be used to disable the CG encode circuit to allow the serviceman to make transmitter distortion and modulation checks without removing the cover from the radio. Temporarily shorting P910-9 (CG DISABLE) to P910-11 (A+) at the rear of the radio applies A+ to ENCODE/DECODE DISABLE lead P1005-10. The A+ is dropped across voltage dividers R1018 and R1019, applying approximately 1.7 volts to the base of Q1001. This base voltage turns on Q1001, causing the collector voltage to go low (near ground potential). This low

potential is applied to Pin 11 of the encoder/decoder hybrid and disables the encode circuit.

CAUTION

DO NOT remove the microphone from the CG hookswitch or press the desk microphone MONITOR switch while using the encode disable jumper. To do so will short the 8.5 volt regulator on the TX/RX board to ground through the hookswitch (or desk mic.), and damage to the equipment will result.

TROUBLESHOOTING PROCEDURE

Before starting the TROUBLESHOOTING PROCEDURE, check to see that 8.5 volts and A+ are present at P1005.

SYMPTOM:

No Encode Tone

Check the PTT all the CG ENCODE/DECODE leads at P1005 for a "low" (0.7 volt or less). If a "low" is not present, check the microphone and hookswitch circuits. If a "low" is present, check the DELAY CLOCK output at U1003-9 for 64 Hz, and the TONE CLOCK output at U1003-8 for being 256 times the Channel Guard (CG) frequency.

EXAMPLE:

If the CG frequency is 100 Hz, the TONE CLOCK output should be 25,600 Hz. If either clock output is not present, replace U1003. If both clock outputs are correct, check U1001-5 for a tone output. If no tone is present, replace U1001.

Encode Disable (Tone present when CG disabled)

Key the microphone and check for a tone output at P1005-4. If no tone output, make the checks listed for "No Encode Tone". If tone is present, apply a "high" (approx. 8 VDC) to the CG ENC/DEC DISABLE lead (P1005-10). Tone should not be present at CG HI lead (P1005-4). If tone is present, check for a low of approx. 0.2 VDC at the collector of Q1001. If the collector is low and tone is still present at P1005-4, replace U1001. If the collector voltage is over 1.0 VDC, check Q1001 and associated circuitry.

No Decode (Receiver won't unsquelch)

With the correct CG tone applied and the CG ENC/DEC Disable lead high, RX MUTE (P1005-9) lead should be "high" (8 VDC) or open. If not, check the clock outputs at U1003-8 (256 x CG Freq.) and U1003-9 (64 Hz). If clock outputs are incorrect, replace U1003. If clock outputs are correct, replace U1001.

Decode Disable (Receiver won't unsquelch with CG disabled)

With the correct CG tone applied to VOL/SQ HI (P1005-2), the RX MUTE lead should go "high". Next, ground the CG ENC/DEC DIS input and check to see that the RX MUTE lead goes "low" (<0.2 V). If not replace U1001.

Wrong Encode or Decode Tone

Check that S1001 is programmed for the correct CG frequency (refer to the FREQUENCY PROGRAMMING INSTRUCTIONS).

If S1001 is set correctly, check the tone programming pins at U1003-2 through -7 and -10 through -13.

NOTE:

Logic "1" is approx. supply voltage and logic "0" is approx. A-. If logic readings correspond to S1001 settings, replace U1003. If readings do not correspond to S1001 settings, replace S1001.

No Tone Reject Filter Output

With no filter output, apply a 1000 Hz 300 millivolt signal to P1005-2. If the reading at Pin 1 of U1004-A is the same as the input signal,

check U1004-B and associated components. If there is no output at Pin 1, check U1004-A and associated components.

Audio output of filter contains excessive noise (motorboating, rumble, etc)

Check CG MODULATION control R1004. The modulation should be no greater than 1 kHz deviation.

Apply 100 Hz to P1005-2. Check at P1005-1 for more than 30 dB of attenuation. If output is not attenuated by at least 30 dB, check U1004 and associated circuitry.

Apply 100 Hz and then 1000 Hz to P1005-2 and compare the RMS output reading. The 100 Hz input should be attenuated at least 30 dB (or greater) compared to the 1000 Hz input.

Squelch Tail Present (no STE)

When the PTT lead is "low", P1005-8 should be "low". When the PTT lead goes "high" (PTT released), the PTT DELAYED lead should remain "low" for an additional 160 milliseconds. If not, replace U1001.

TECHNICAL SPECIFICATIONS

Input Voltage

8.5 V DC

Current Drain

40 mA Max.

Frequency Range

67-210.7 Hz

Maximum Frequency Error

±0.2%

Encode Output Level

67 Hz - 0.7 V RMS Minimum

156.7 Hz - 0.35 V RMS Minimum

210.7 Hz - 0.15 V RMS Minimum

Encode Tone Distortion

2% Max.

Programming Increments

0.25 Hz

Decode Level

35 Millivolts RMS Minimum

Decode Response Time

250 Milliseconds Max.

PTT Delay

160 Milliseconds

S/E Phase Shift

135°

Temperature Range

-35°C to + 60°C

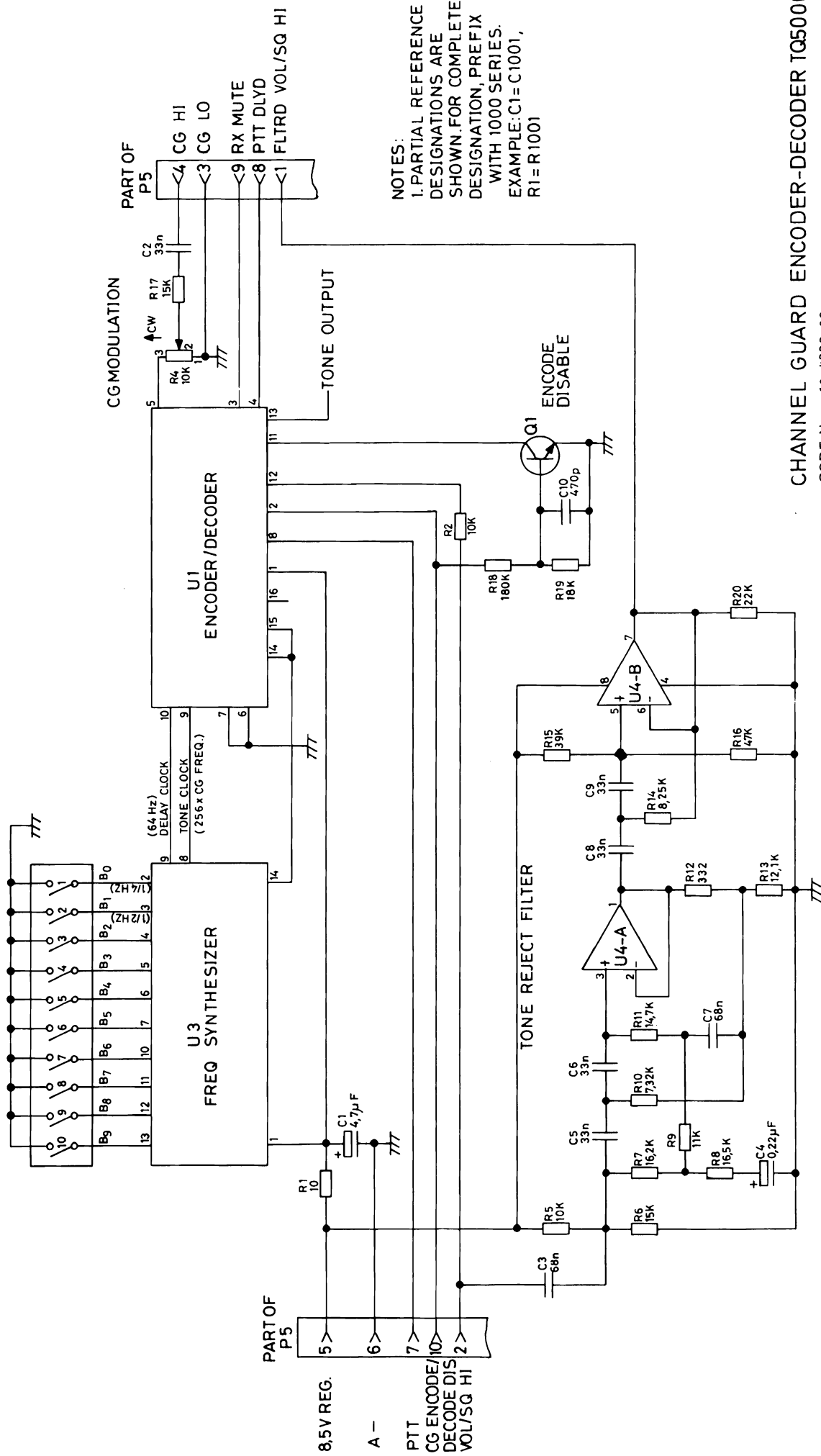

NOTES:
 1. PARTIAL REFERENCE DESIGNATIONS ARE SHOWN. FOR COMPLETE DESIGNATION, PREFIX WITH 1000 SERIES. EXAMPLE: C1 = C1001, R1 = R1001

CHANNEL GUARD ENCODER-DECODER TQ5006

CODE No.: 10.4222-00

SUB. ASM. 10.5018-00 (19C850801G1)

D403.010/2

Storno

Nº	CODE	DATA
C1001	19A134202P5	3. 3 uF Tantal
C1002	19A700005P10	33 nF Polyester
C1003	19A116080P206	68 nF Polyester
C1004	19A134202P10	0. 22 uF Tantal
C1005	19C300075P33001G	33 nF Polyester
C1006	19C300075P33001G	33 nF Polyester
C1007	19C300075P68001G	68 nF Polyester
C1008	19A700005P10	33 nF Polyester
C1009	19A700005P10	33 nF Polyester
C1010	19A116192P2	470 pF Ceram capacitor
P1005	19A134152P35	Connector
Q1001	19A115910P1	Transistor
R1001	19A700019P13	10 ohm Resistor
R1002	19A700019P49	10 Kohm Resistor
R1003	19A700019P42	2. 7 Kohm Resistor
R1004	19A116559P206	10 Kohm Resistor var.
R1005	19A700019P49	10 Kohm Resistor
R1006	19A700019P51	15 Kohm Resistor
R1007	19C314256P21622	16. 2 Kohm Metal film
R1008	19C314256P21652	16. 5 Kohm Metal film
R1009	19C314256P21102	11 Kohm Metal film
R1010	19C314256P27321	7. 32 Kohm Metal film
R1011	19A314256P21472	14. 7 Kohm Metal film
R1012	19A701250P151	330 ohm Metal film
R1013	19C314256P21212	10 Kohm Metal film
R1014	19C314256P28251	8. 2 Kohm Metal film
R1015	19A700019P56	39 Kohm Resistor
R1016	19A700019P57	47 Kohm Resistor
R1017	19A700019P51	15 Kohm Resistor
R1018	19A700019P61	100 Kohm Resistor
R1019	19A143400P52	20 Kohm Resistor Depos
R1020	19A143400P52	20 Kohm Resistor Depos
R1021	19A700019P34	560 ohm Resistor
S1001	19B800010P1	Switch
U1001	19D430412G1	Int. Circuit
U1003	19D430393G1	Int. Circuit
U1004	19A134511P2	Int. Circuit

Storno

Nº	CODE	DATA

CHANNEL GUARD ENC/DEC TQ5006

X403. 022

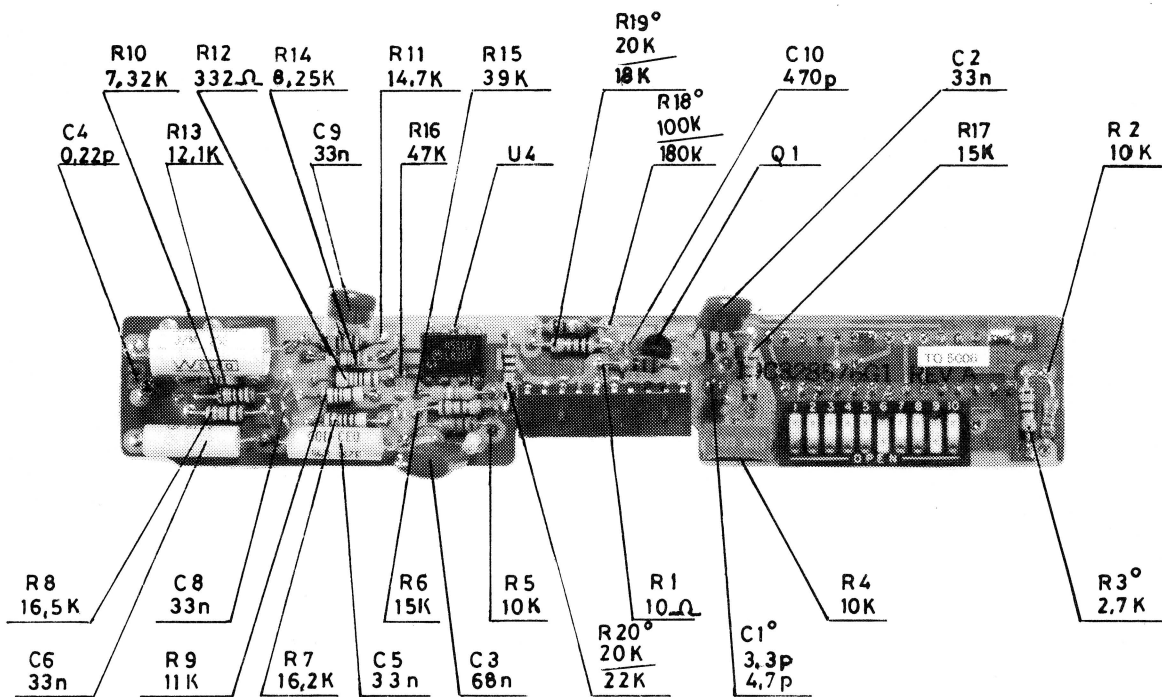

INSTALLATION, PROGRAMMING AND ADJUSTMENT

TQ5006, TR5002, TT5002, FN5002

INSTALLATION

The TQ5006 module is inserted and connected to the XS/FS board on the J905 connector.

The following jumper wires on the XS/FS board are cut:

- For TQ5006 - cut H7-H8 and H9-H10-H20-H33
- For TT5002 - cut H9-H10
- For TR5002 - cut H7-H8
- For FN5002 - cut H7-H8

PROGRAMMING

The Channel Guard module is programmed to a specific tone of the CTCSS series by setting a 10 position binary switch.

The switch positions have the following weights (Hz).

The programmed frequency is the sum of the open switches.

SW position	1	2	3	4	5	6	7	8	9	10
Freq. Hz	0.25	0.5	1	2	4	8	16	32	64	128

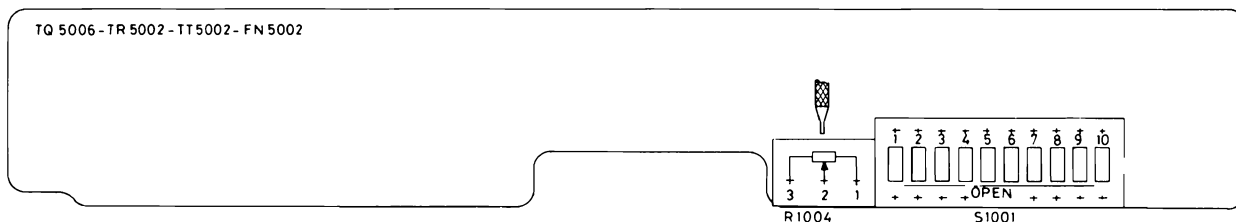

PROGRAMMING AND ADJUSTMENT TQ5006

D403.044

STANDARD TONE FREQUENCIES, Hz (CTCSS)

67.0				
71.9	88.5	107.2	131.8	162.2
74.4	91.5	110.9	136.5	167.9
77.0	94.8	114.8	141.3	173.8
79.7	97.4	118.8	146.2	179.9
82.5	100.0	123.0	151.4	189.2
85.4	103.5	127.3	156.7	192.8
				203.5
				210.7

EXAMPLE

Channel Guard tone= 103.5 Hz

$$103.5 = 64 + 32 + 4 + 2 + 1 + 0.5$$

Switch	1	2	3	4	5	6	7	8	9	10
Position	0	1	1	1	1	0	0	1	1	0

1= OPEN 0= CLOSED

Channel Guard tone= 156.7 Hz (round off to 156.75 Hz)

$$156.75 = 128 + 16 + 8 + 4 + 1 + 0.5 + 0.25$$

Switch	1	2	3	4	5	6	7	8	9	10
Position	1	1	1	0	1	1	1	0	0	1

1= OPEN 0= CLOSED

ADJUSTMENT OF FREQUENCY DEVIATION

Disable the Channel Guard modulation by applying +8.5 V DC to pin 9 on the rear connector J910 (CG disable). This pin is floating during normal operation and if pulled "low" the Channel Guard receiver function is disabled.

Adjust, as described in the CQM5000 Adjustment Procedure, the modulation frequency deviation such that the frequency deviation is equal to the maximum permissible frequency deviation minus the Channel Guard frequency deviation.

The channel guard modulation is as follows, or as specified by the customer:

25 kHz	channel spacing	± 750 Hz
20 kHz	channel spacing	± 600 Hz
12.5 kHz	channel spacing	± 375 Hz

Remove the AF modulation.
Remove the 8.5 V DC to pin 9 on the rear connector J910.
Key the transmitter.

Adjust potentiometer R1004 for correct Channel Guard frequency deviation.

Connect a frequency counter to the AF output on the deviation meter.

Check the accuracy of the channel guard tone.
Requirement: $f_{nom} \pm 0.2\%$

CHANNEL GUARD DECODING CHECK

Use receiver test setup.
Modulate the RF generator with the channel guard tone to specified frequency deviation.

Check that the decoder opens the AF channel if and only if the channel guard tone is present.

Connect an AF voltmeter to the AF output load.

Measure the channel guard tone level.

Requirement: -17 dB below the level produced by a signal which is modulated with 1 kHz to 60% of maximum frequency deviation.

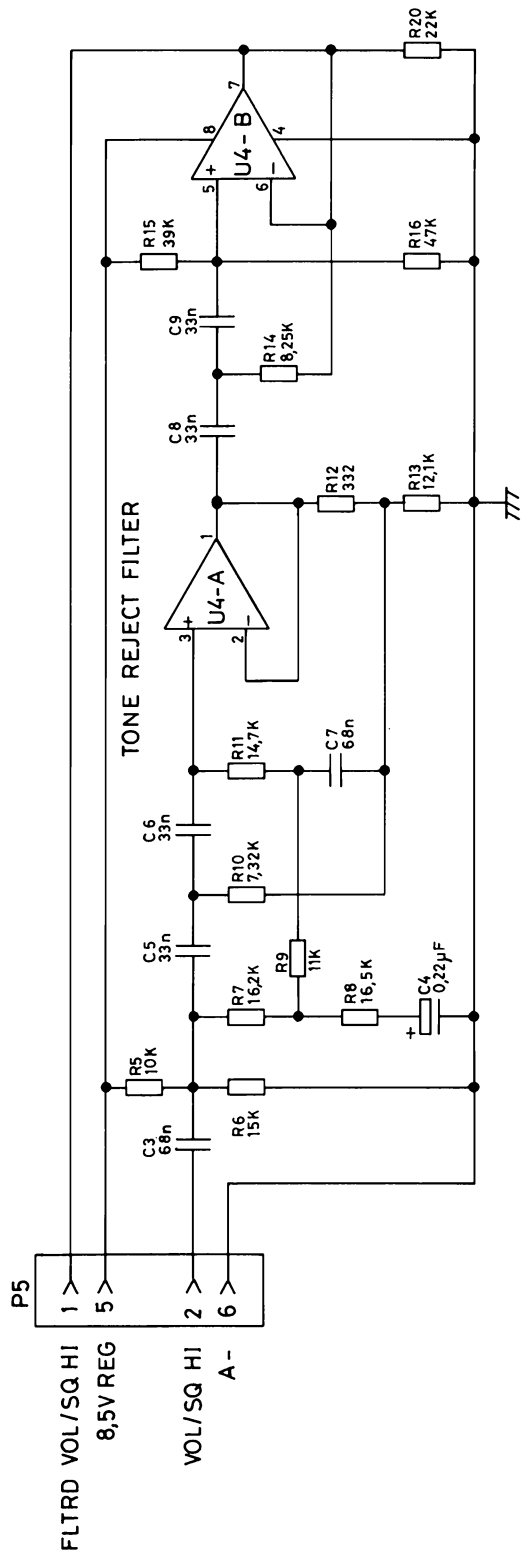

NOTES:
1. PARTIAL REFERENCE DESIGNATIONS ARE SHOWN .
FOR COMPLETE DESIGNATION, PREFIX WITH 1000SERIES.
EXAMPLE: C1=C1001, R1=R1001ETC.

CHANNEL GUARD TONE REJECT FILTER FN5002

CODE No. : 10. 4225-00

SUB. ASM. 10. 5021-00 (19C850801G4)

D403.008/2

Stormo

Nº	CODE	DATA
C1003	19A116080P206	68 nF Polyester
C1004	19A134202P10	0.22 uF Tantal
C1005	19C300075P33001C	33 nF Polyester
C1006	19C300075P33001C	33 nF Polyester
C1007	19C300075P68001C	68 nF Polyester
C1008	19A700005P10	33 nF Polyester
C1009	19A700005P10	33 nF Polyester
P1005	19A134152P35	Connector
R1005	19A700019P49	10 Kohm Resistor
R1006	19A700019P51	15 Kohm Resistor
R1007	19C314256P21622	16.2 Kohm Metal film
R1008	19C314256P21652	16.5 Kohm Metal film
R1009	19C314256P21102	11 Kohm Metal film
R1010	19C314256P27321	7.32 Kohm Metal film
R1011	19A314256P21472	14.7 Kohm Metal film
R1012	19A701250P151	330 ohm Metal film
R1013	19C314256P21212	10 Kohm Metal film
R1014	19C314256P28251	8.2 Kohm Metal film
R1015	19A700019P56	39 Kohm Resistor
R1016	19A700019P57	47 Kohm Resistor
R1020	19A143400P52	20 Kohm Resistor Depos
U1004	19A134511P2	Int. Circuit

Stormo

Nº	CODE	DATA

CHANNEL GUARD TONE REJECT FILTER FN5002

X403.019

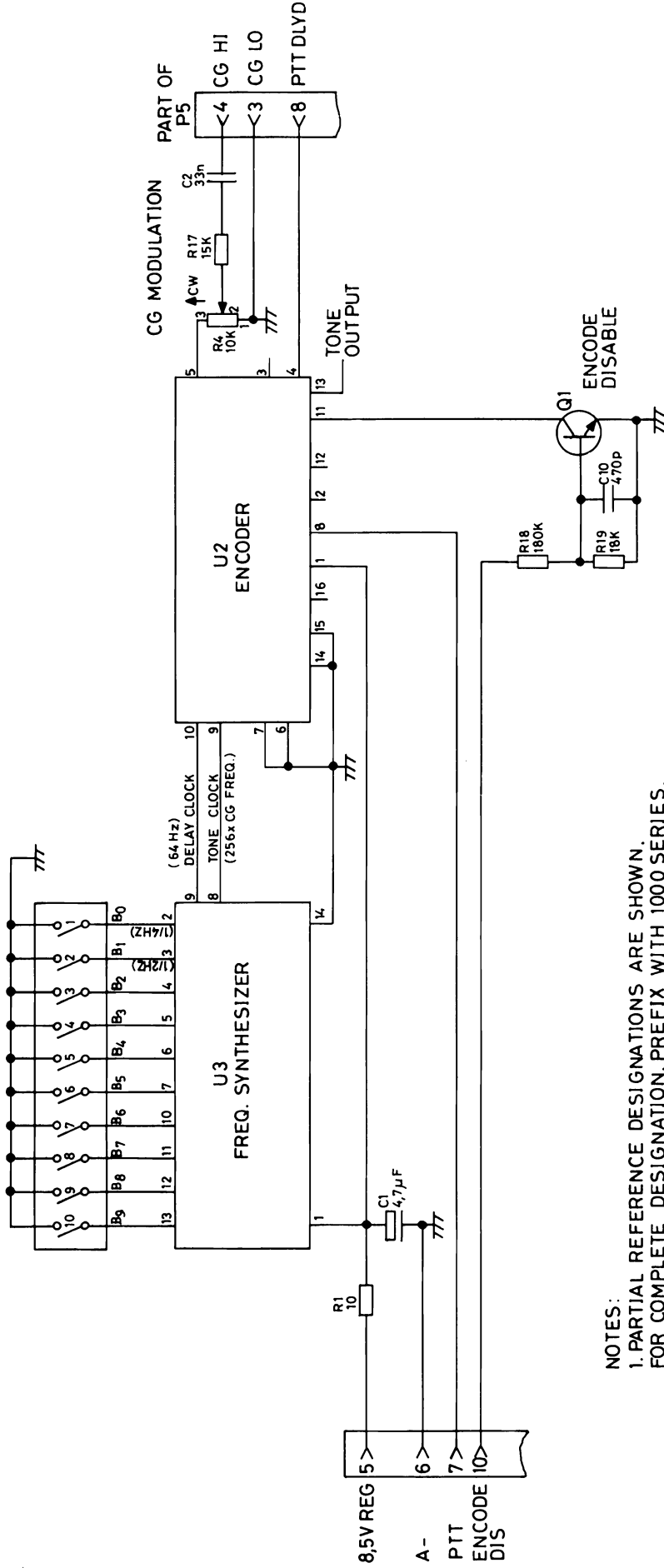

NOTES:
 1. PARTIAL REFERENCE DESIGNATIONS ARE SHOWN.
 FOR COMPLETE DESIGNATION, PREFIX WITH 1000 SERIES.
 EXAMPLE: C1 = C1001, R1 = R1001

CHANNEL GUARD ENCODE TT5002

D403.009/2

CODE No.: 10.4223-00

SUB. ASM. 10.5019-00 (19C850801G2)

Storno

N ^o	CODE	DATA
C1001	19A134202P5	3.3 uF Tantal
C1002	19A700005P10	33 nF Polyester
C1010	19A116192P2	470 pF Ceram capacitor
P1005	19A134152P35	Connector
Q1001	19A115910P1	Transistor
R1001	19A700019P13	10 ohm Resistor
R1004	19A116559P206	10 Kohm Resistor var.
R1017	19A700019P51	15 Kohm Resistor
R1018	19A700019P61	100 Kohm Resistor
R1019	19A143400P52	20 Kohm Resistor Depos
S1001	19B800010P1	Switch
U1002	19D430412G2	Int. Circuit
U1003	19D430393G1	Int. Circuit

50 V

0.2 W

0.2 W

0.2 W

Storno

N ^o	CODE	DATA

CHANNEL GUARD ENC TT5002

X403.021

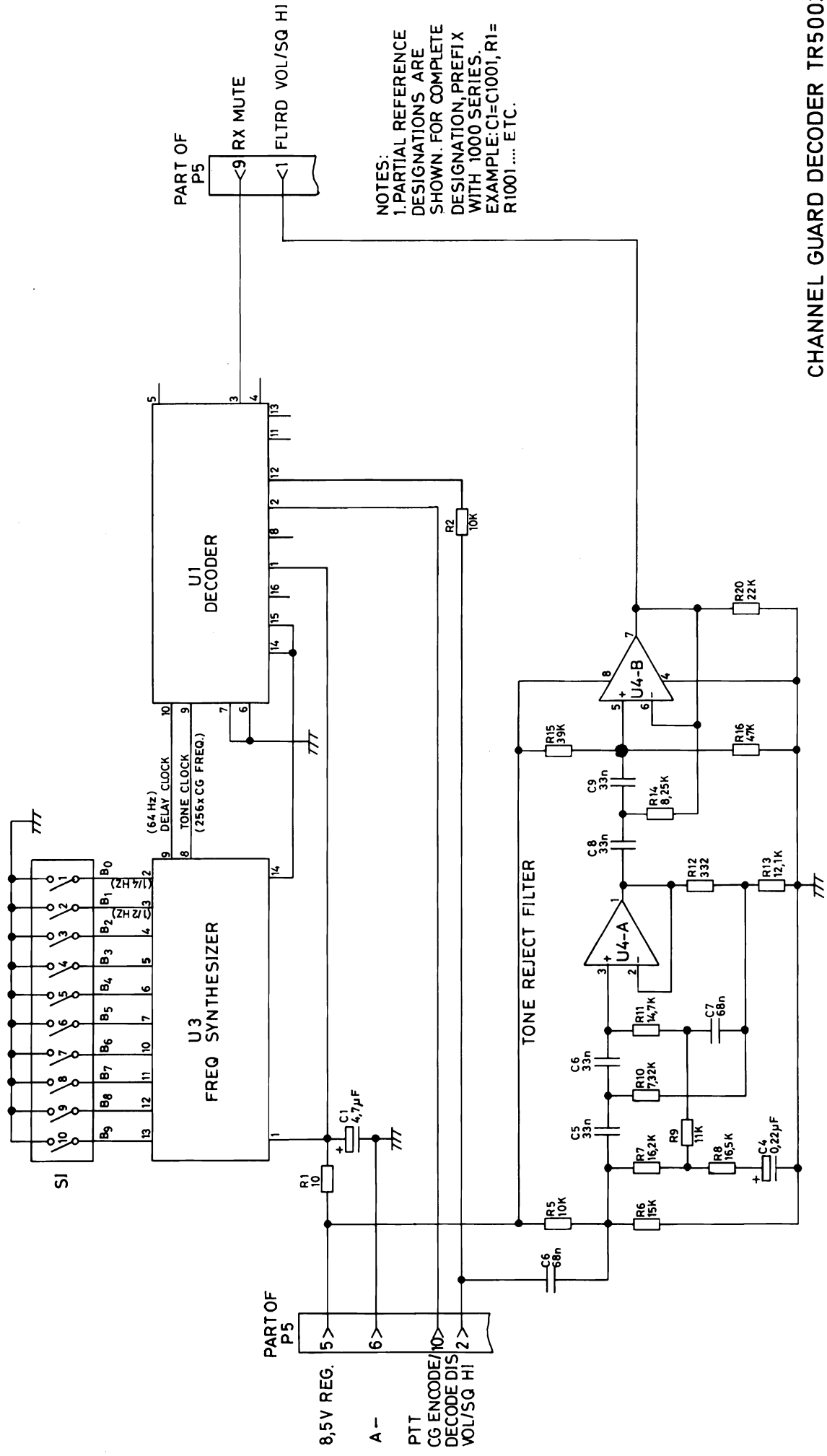

CHANNEL GUARD DECODER TR5002

CODE No.: 10.4224-00

SUB. ASM. 10.5020-00 (19C850801C3)

D403.007/2

Storno

Nº	CODE	DATA
C1001	19A134202P5	3.3 uF Tantal
C1003	19A116080P206	68 nF Polyester
C1004	19A134202P10	0.22 uF Tantal
C1005	19C300075P333001G	33 nF Polyester
C1006	19C300075P333001G	33 nF Polyester
C1007	19C300075P68001G	68 nF Polyester
C1008	19A700005P10	33 nF Polyester
C1009	19A700005P10	33 nF Polyester
P1005	19A134152P35	Connector
R1001	19A700019P13	10 ohm Resistor
R1002	19A700019P49	10 Kohm Resistor
R1003	19A700019P42	2.7 Kohm Resistor
R1005	19A700019P49	10 Kohm Resistor
R1006	19A700019P51	15 Kohm Resistor
R1007	19C314256P21622	16.2 Kohm Metal film
R1008	19C314256P21652	16.5 Kohm Metal film
R1009	19C314256P21102	11 Kohm Metal film
R1010	19C314256P27321	7.32 Kohm Metal film
R1011	19A314256P21472	14.7 Kohm Metal film
R1012	19A701250P151	330 ohm Metal film
R1013	19C314256P21212	10 Kohm Metal film
R1014	19C314256P28251	8.2 Kohm Metal film
R1015	19A700019P56	39 Kohm Resistor
R1016	19A700019P57	47 Kohm Resistor
R1020	19A143400P52	20 Kohm Resistor Depos
R1021	19A700019P34	560 ohm Resistor
S1001	19B800010P1	Switch
U1001	19D430412G1	Int. Circuit
U1003	19D430393G1	Int. Circuit
U1004	19A134511P2	Int. Circuit

Storno

Nº	CODE	DATA

CHANNEL GUARD DEC TR5002

X403.020

PROGRAMMABLE TONE BOARDS

TQ5007/5008

The tone boards TQ 5007/5008 are combined tone transmitter - tone receiver units, universal programmable. TQ 5007/8 are used in connection with Control Logic board CL 5001 or a similar board which is able to program the units, to control the transmitter and to handle the detected outputs.

The TQ unit is built up around a DTD-chip, Digital Tone Decoder, placed on a thick film substrate.

The peripheral circuits are:

a limiter which shapes the input signals to the DTD

an integrator which ensures proper detection of the detected output.

In tone generator mode a summation network generates the output signal from two square waves sent out from the DTD. This summation network is enabled from the control logic by two three-state buffers when the TQ is used as a tone transmitter.

After being filtered and deemphasized, the final signal is applied to the microphone amplifier.

TQ 5007 has only one DTD-substrate, A101, which detects and/or transmits tone signal for individual calls.

TQ 5008 has two DTD-substrates, A101 and A102, which detect and/or transmit tone signals for individual calls, group calls and all calls.

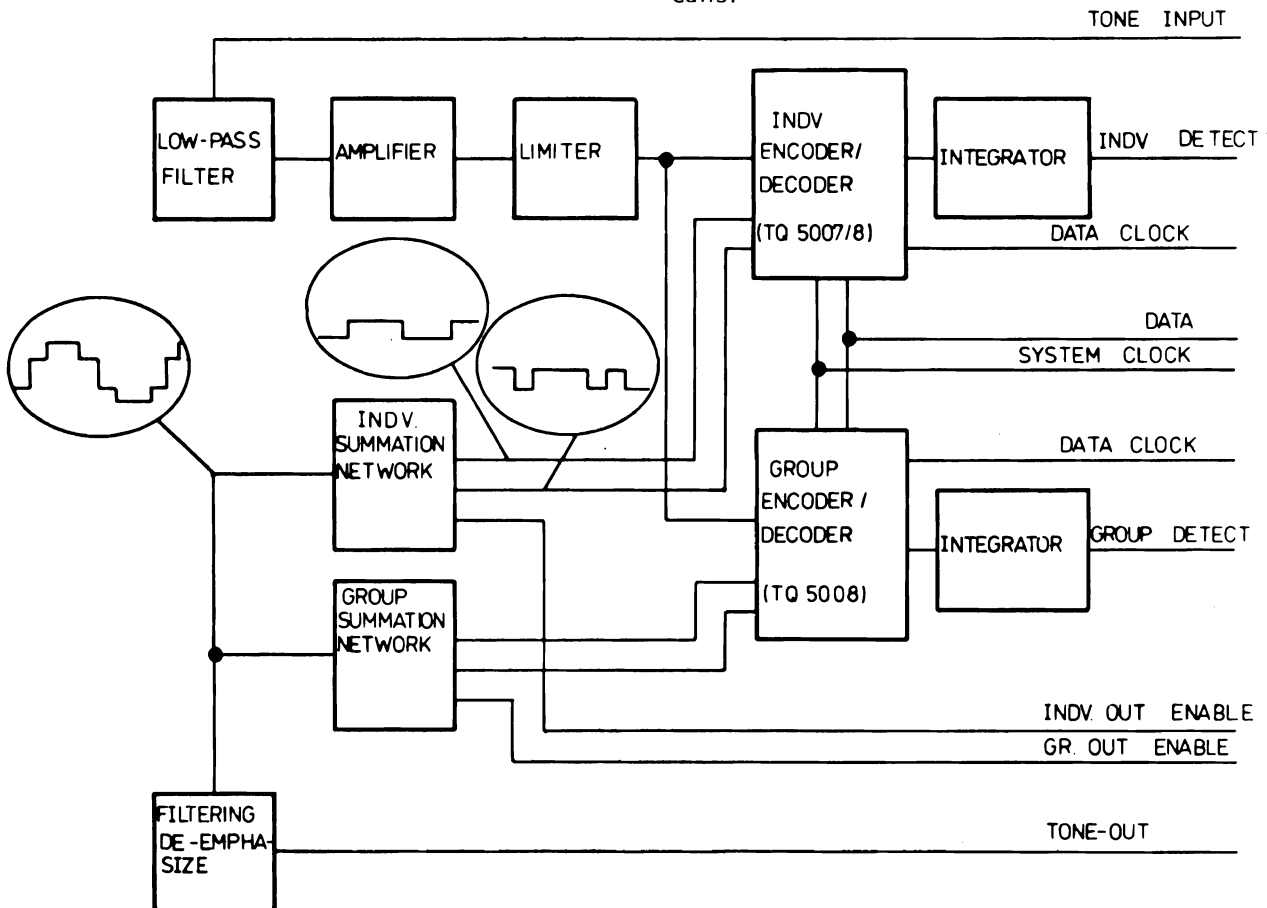

FUNCTIONAL DIAGRAM TQ5007/8

D403.066

TQ-LOADING

All connections on the TQ take place through connector J101 which is connected to P801 on the Control Logic board CL 5001.

A system clock, output from the counter U814 on the CL board is fed to the circuit through pin 2 at the connector. The system clock is 223,72 KHz which is the microcomputer's clock frequency divided by 16.

To set up a tone, the DTD is loaded with 15 bits serially clocked in by a data clock. The first 5 bits determine the circuit Q-value (see programming manual, add. 32H in the personality prom.)

The last 10 bits program the tone frequency either to be received or to be transmitted by the TQ unit (see programming manual add. 08-13H)

These bits and the data clock are sent to the TQ unit from the microcomputer on CL 5001 via pin 1 and 5/6 on connector J101 (via pin 5 to be loaded on DTD chip A101, via pin 6 to be loaded on DTD chip A102).

TONERECEPTION

As soon as the radio is turned on, the system clock starts the TQ unit and the Control Logic board CL 5001 loads the 15 bits corresponding to the first tone synchronously with the data clock in A101. When a tone call is received, the first tone of the sequence enters pin 9 at connector J101.

The sinusoidal signal passes through a 2 pole active low-pass filter built around the operational amplifier U101a. The signal is then am-

plified by a factor 10 in the amplifier U101b and finally limited by the comparator (Schmitt-trigger) U101c.

The obtained square-waved signal is sent to the detect input (7) of the DTD, A101 (and A102 if TQ5008).

The DTD, which is to be considered as a programmable digital filter, compares the signal with the programmed tone clocked in by the data clock. The detect output of A101 (or A102 if group/all call) goes HIGH if the entered signal is accepted. To ensure a reliable detect acknowledgement, the detected output is processed by the integrator U101d or U103. The delayed output of U101d is connected to pin 11, the delayed output of U103 (in connection with A102 in TQ5008) is connected to pin 12 on J101. Both detect outputs are active LOW.

Note: The data clock inputs must be LOW in receiver mode, otherwise the detect outputs are inhibited.

TONE TRANSMISSION

When the tone key is depressed, pin 7 on connector J101 goes LOW and enables U102 which is an hex non-inverting tri-state buffer. The 15 programming bits are loaded into the DTD chips synchronously with the data clock. The DTD chip generates two square wave signals at the outputs 13 and 15. These two different signals are loaded into U102 and summed, but differently weighted by the resistors R12 and R13. This output signal is then filtered and deemphasized to become a sinusoidal signal which is sent via pin 10 at connector J101 to the microphone amplifier on the RF-board.

TECHNICAL SPECIFICATIONS

Voltage supply

5.0 V

Current consumption

TQ 5007: 25 mA \pm 5 mA

TQ 5008: 50 mA \pm 5 mA

Temperature range (ambient)
-30°C to +60°C

Weight
60 g.

Dimensions
150 x 40 x 10 mm

TONE TRANSMITTER

Output impedance
typical 25 Kohm

Signal output voltage
min. 250 mV e.m.f., 1060 Hz
typical 280 mV

Frequency response
De-emphasized, Fc= 500 Hz
Tolerance:
± 1 dB

Distorsion
< 5 %

Frequency error
< 0,01 %

TONE RECEIVER

Input impedance
> 30 kohm

Input response
Low-pass, Fc= 3100 Hz

Activating level
300 mV ± 6 dB

Distorsion
The tone receiver will accept tones
with up to 20% distortion.

Selectivity
With Q-value= 32, TQ 5007/8 is not sensitive
to adjacent tones or other tones of the same
standard series.

Reaction time
20 ms < r < 45 ms

Signal to noise conditions
Tone receiver accepts a noise level:
SINAD= 5 dB.

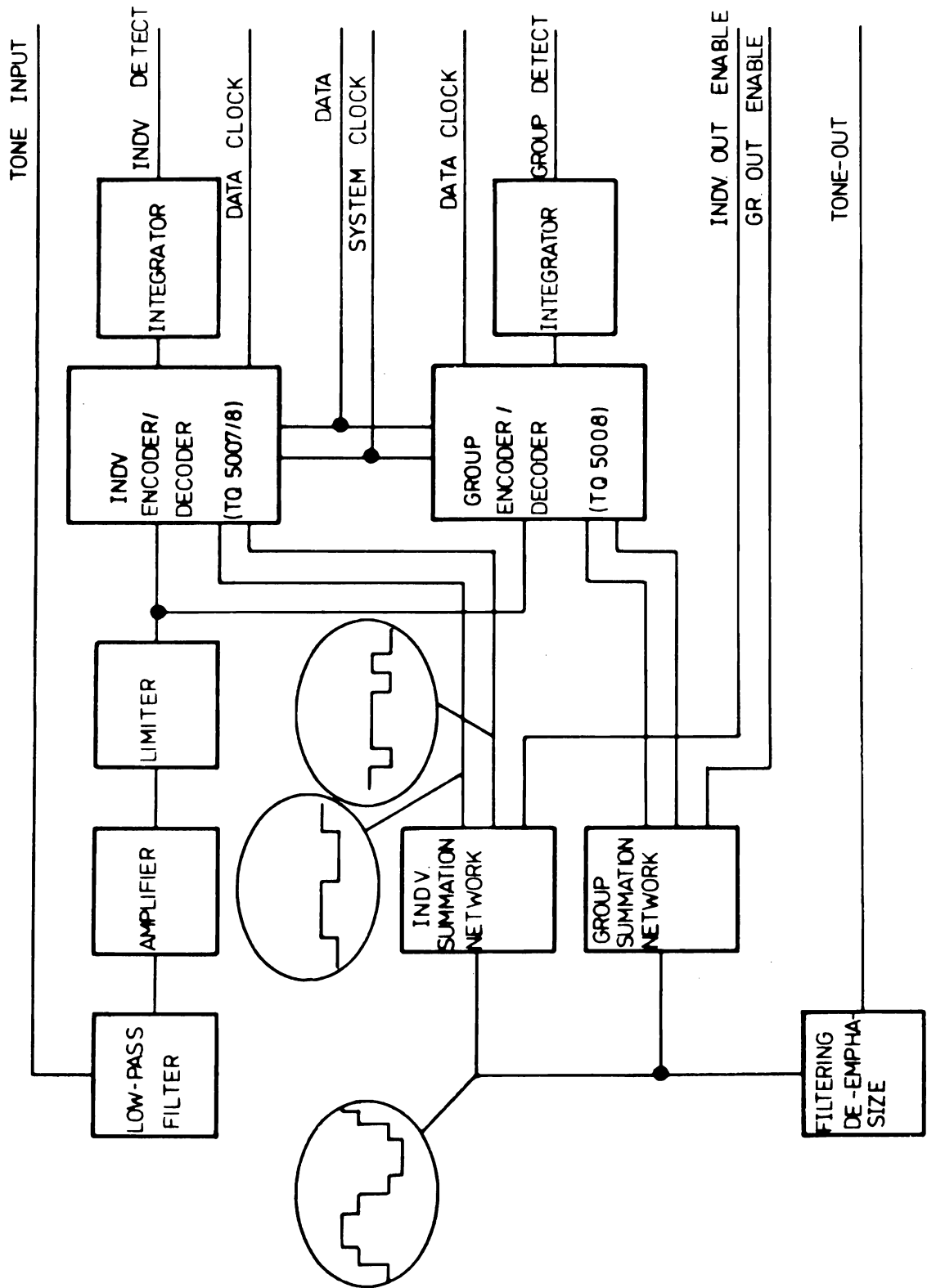

FUNCTIONAL DIAGRAM TQ5007, TQ5008

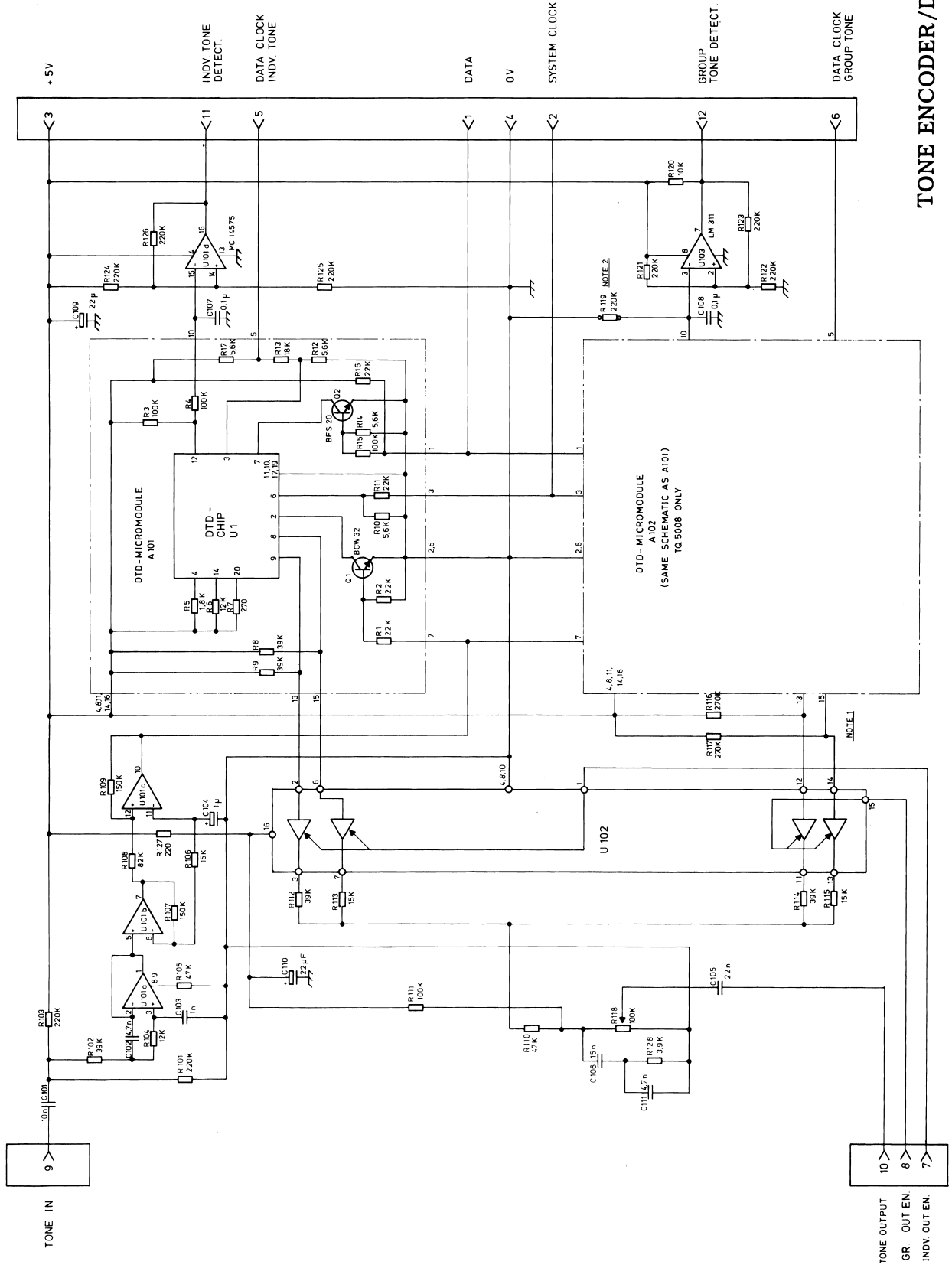

NOTE 1:
FOR TQ5007 DO NOT MOUNT A102
FOR TQ5006 MOUNT A102

NOTE 2:
FOR TQ5007 R119 IS MOUNTED
FOR TQ5008 R119 IS DISMOUNTED

TONE ENCODER/DECODER TQ5007, TQ5008

N ₀	CODE	DATA
	M905144G1	TQ5007
	M905144G2	TQ5008
A101	M905148G1	Assem., Micromodule-incl. Digital Tone Det.
A102 ⁺	M905148G1	Assem., Micromodule-incl. Digital Tone Det.
C101	A700005P7	Capacitor, 10 nF 5%, Polyest. 50 V
C102	A700005P5	Capacitor, 4,7 nF 5%, Polyest. 50 V
C103	A700005P1	Capacitor, 1 nF 5%, Polyest. 50 V
C104	A701352P7	Capacitor, 1 µF -10+100%, Elco 6,3 V
C105	A700005P9	Capacitor, 22 nF 5%, Polyest. 50 V
C106	A700005P8	Capacitor, 15 nF 5%, Polyest. 50 V
C107	A700004P2	Capacitor, 0,1 µF 5%, Polyest. 50 V
C108	A700004P2	Capacitor, 0,1 µF 5%, Polyest. 50 V
C109	J706339P8	Capacitor, 22 µF -10+100%, Elco 50 V
C110	J706339P8	Capacitor, 22 µF -10+100%, Elco 50 V
C111	A700005P5	Capacitor, 4,7 nF 5%, Polyest. 50 V
J101	J706215P112	Connector, 12 Pin, Male.
R101	A700019P65	220 Kohm 5%, Resistor, carb. film 0,25 W
R102	A700019P56	39 Kohm 5%, Resistor, carb. film 0,25 W
R103	A700019P65	220 Kohm 5%, Resistor, carb. film 0,25 W
R104	A700019P50	12 Kohm 5%, Resistor, carb. film 0,25 W
R105	A700019P57	47 Kohm 5%, Resistor, carb. film 0,25 W
R106	A700019P51	15 Kohm 5%, Resistor, carb. film 0,25 W
R107	A700019P63	150 Kohm 5%, Resistor, carb. film 0,25 W
R108	A700019P60	82 Kohm 5%, Resistor, carb. film 0,25 W
R109	A700019P63	150 Kohm 5%, Resistor, carb. film 0,25 W
R110	A700019P57	47 Kohm 5%, Resistor, carb. film 0,25 W

N ₀	CODE	DATA
R111	A700019P61	100 Kohm 5%, Resistor, carb. film 0,25 W
R112	A700019P56	39 Kohm 5%, Resistor, carb. film 0,25 W
R113	A700019P51	15 Kohm 5%, Resistor, carb. film 0,25 W
R114	A700019P56	39 Kohm 5%, Resistor, carb. film 0,25 W
R115	A700019P51	15 Kohm 5%, Resistor, carb. film 0,25 W
R116	A700019P65	220 Kohm 5%, Resistor, carb. film 0,25 W
R117	A700019P65	220 Kohm 5%, Resistor, carb. film 0,25 W
R118	J706042P1	100 Kohm 10%, Pot. meter-lin. 0,1 W
R119 ^o	A700019P65	220 Kohm 5%, Resistor, carb. film 0,25 W
R120	A700019P49	10 Kohm 5%, Resistor, carb. film 0,25 W
R121	A700019P65	220 Kohm 5%, Resistor, carb. film 0,25 W
R122	A700019P65	220 Kohm 5%, Resistor, carb. film 0,25 W
R123	A700019P65	220 Kohm 5%, Resistor, carb. film 0,25 W
R124	A700019P65	220 Kohm 5%, Resistor, carb. film 0,25 W
R125	A700019P65	220 Kohm 5%, Resistor, carb. film 0,25 W
R126	A700019P65	220 Kohm 5%, Resistor, carb. film 0,25 W
R127	A700019P29	220 ohm 5%, Resistor, carb. film 0,25 W
R128	A700019P44	3,9 Kohm 5%, Resistor, carb. film 0,25 W
U101	J706293P1	MC14575, IC, Dual/Dual Progr. Op.Amp. Comp.
U102	A700029P229	F40097, IC, Hex Tri-State Buffer.
U103	J706579P2	LM311N, IC, Voltage Comparator.

TONE ENCODER/-DECODER TQ5007 and TQ5008

X403.208

NOTES: + used in TQ5008 only

) b us) TQ:) nly.)

Storno

Storno

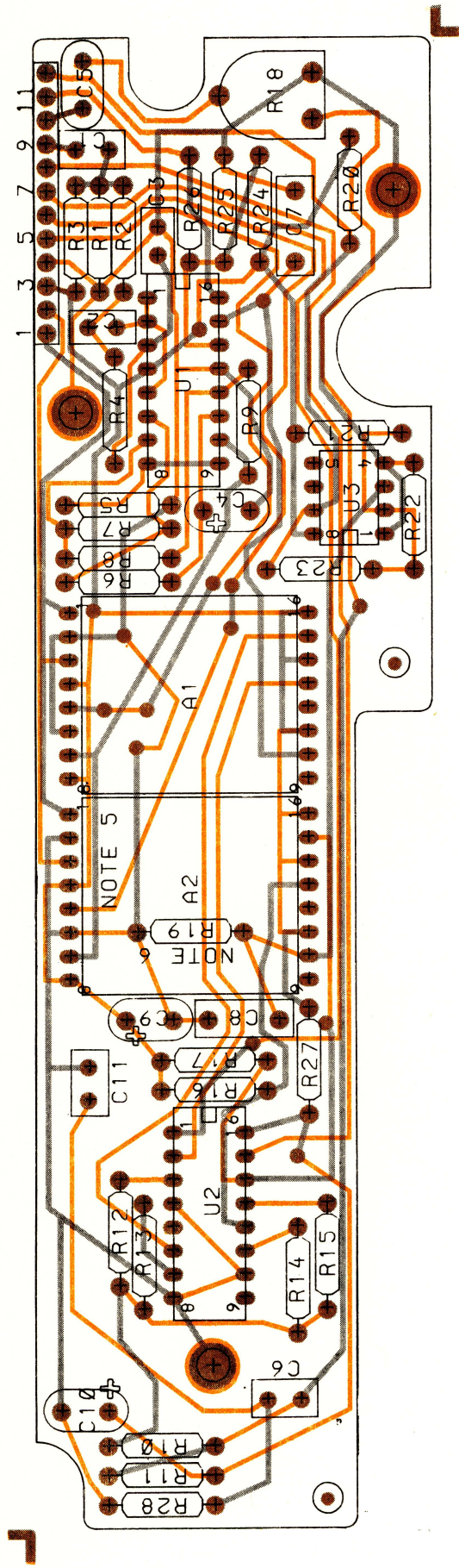

TONE MODULE TQ5007-5008

D403.038